

8055

Technic

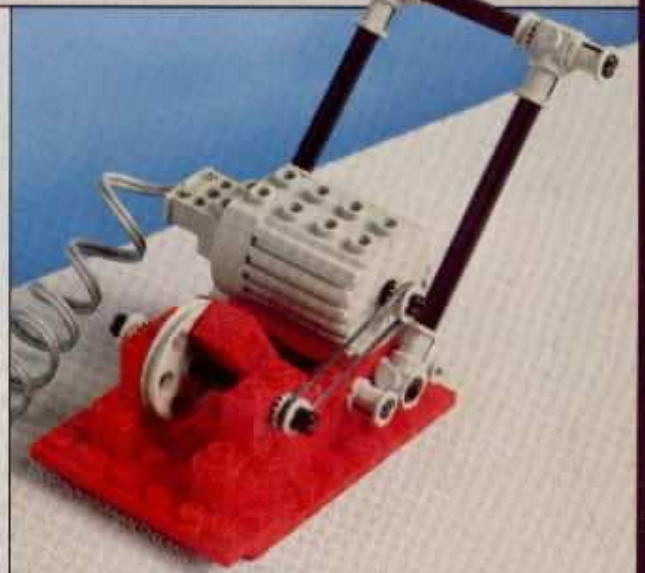

Here's How to Operate Your 4.5 Volt Motor and Battery Control Unit.

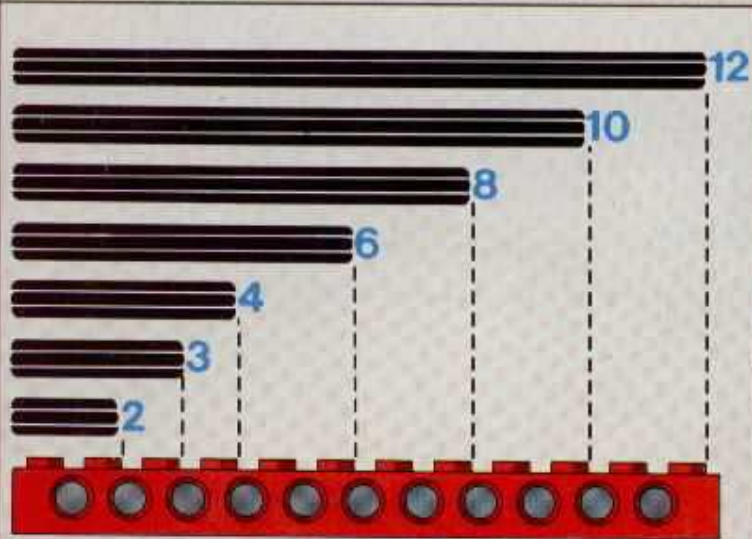
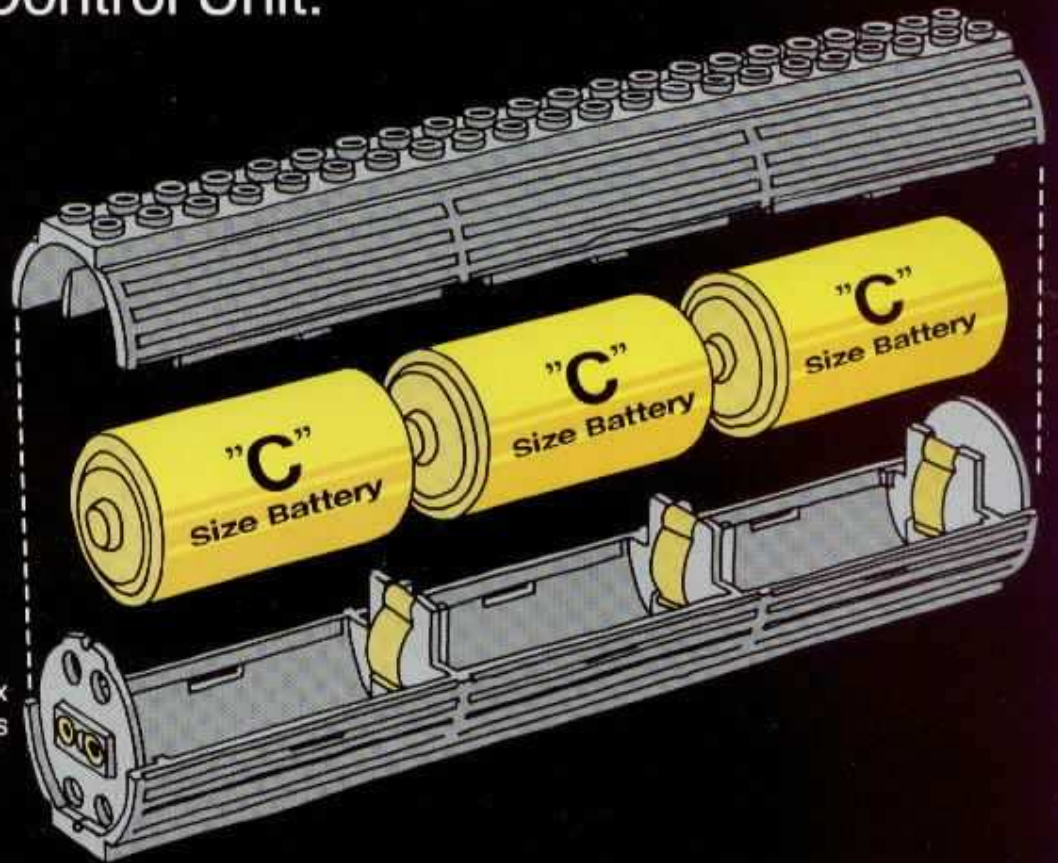

Lift off the lid of the battery box and insert 3 C-size batteries end-to-end as shown. Replace lid. (Batteries not included).

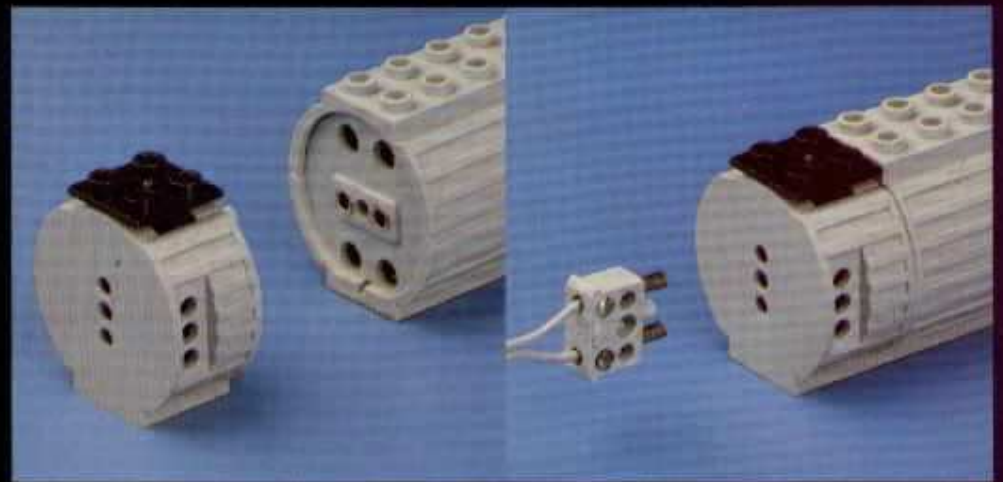

Attach the power control unit directly onto the battery box as shown.

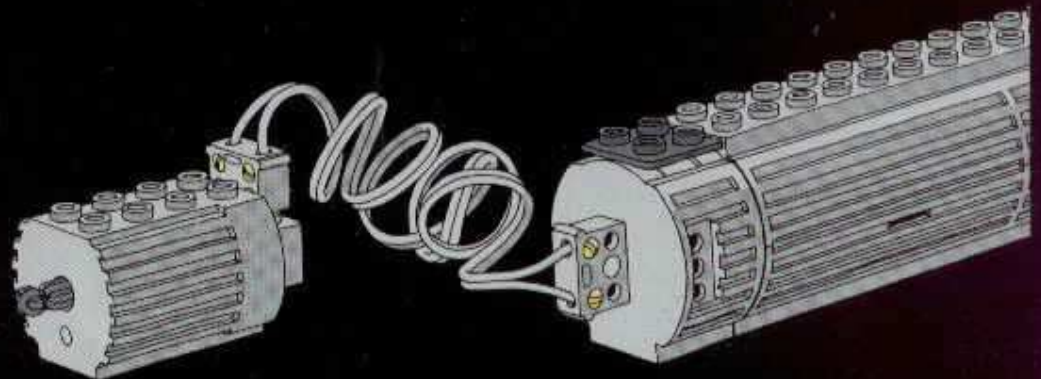

Connect the motor to the battery control unit with the motor wires provided.

To operate the control unit, move the switch side-to-side to go either forward or backward. To turn it off, the switch must be returned to the original position. If the switch is only pushed lightly, it will automatically return to the off position when you let go.

In addition, the power control unit can be built directly onto the motor itself. The power control unit and battery box can be connected with the motor wires.



Helpful Hints

If the control unit doesn't start, then check to see that:

- a. Everything is connected in a firm and secure manner.
- b. The batteries are inserted properly into the battery box.

If the motor still doesn't start, then replace the batteries with new ones.

Batteries:

Use 3 C-size batteries to fit the spaces in the battery box.

Read instructions on batteries carefully before use:

Be certain to install the batteries correctly in the battery box. To do this, observe the polarity signs (+/- symbols).

Incorrect installation when using batteries may result in battery leakage, or cause a short circuit.

Check the batteries regularly. Remove the batteries if they are not used for a long period of time.

Batteries can leak a corrosive fluid, which will damage the battery box. When replacing batteries, replace all at the same time, i.e. never mix used and new batteries.

Do not use different types of batteries (e.g. zinccarbon, alkaline, rechargeable etc.) at the same time.

Rechargeable batteries may be used, however, do not try to recharge the batteries in the battery box, always use a correct recharger.

Do not connect two or more battery boxes.

Be careful when connecting the battery box to the motor or lighting bricks. Never plug the wire back into itself forming a complete loop or into another wire already connected to the battery box. This will cause a short circuit.

Do not throw used batteries in the fire!

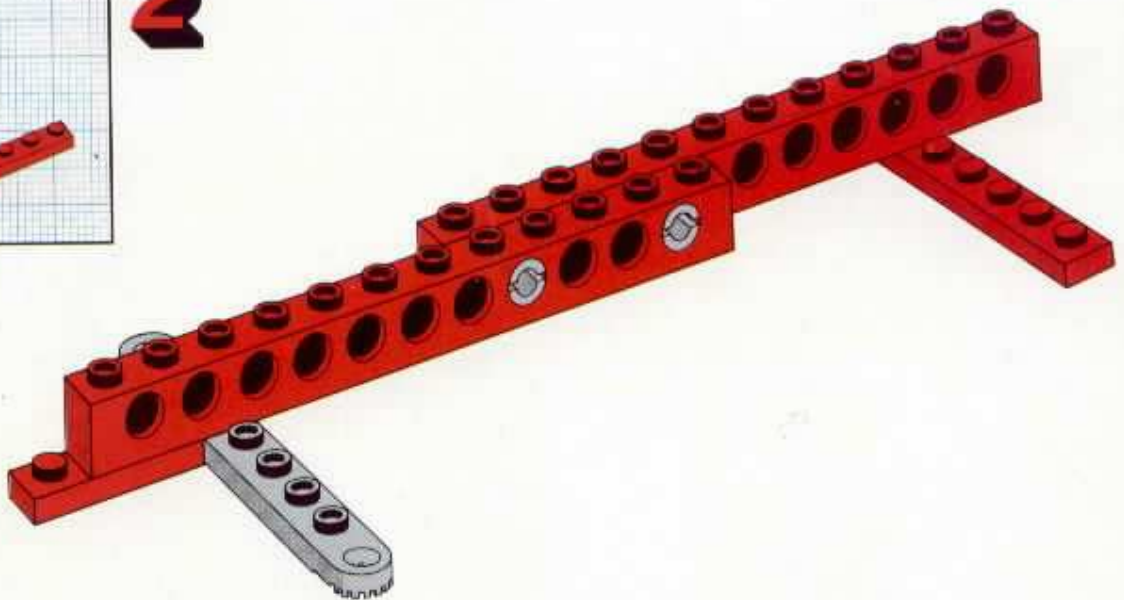
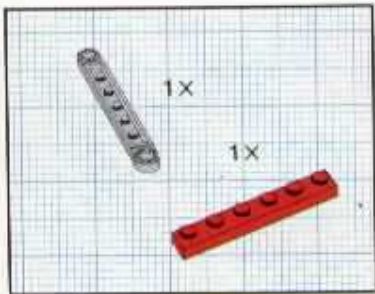
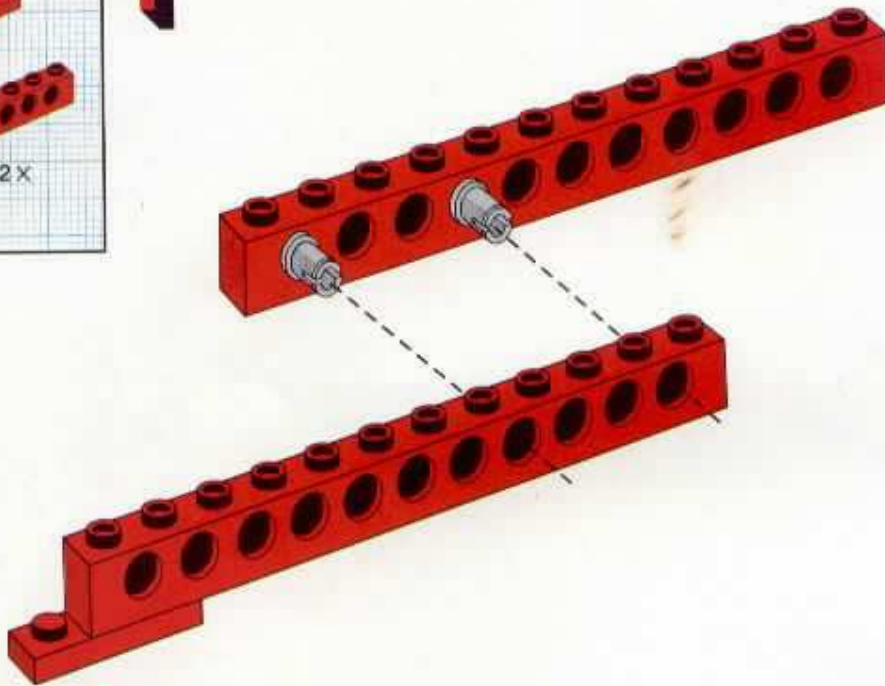
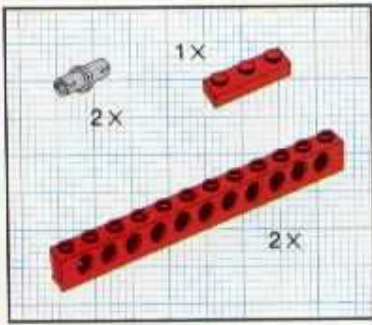

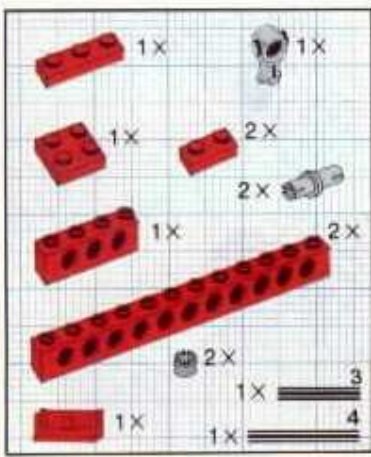

3

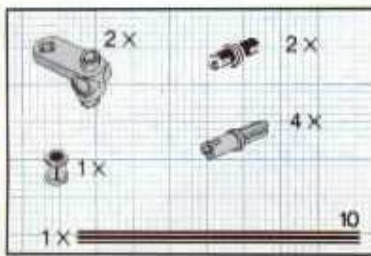
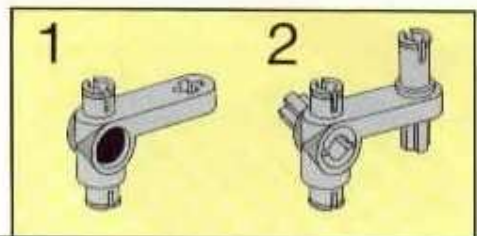
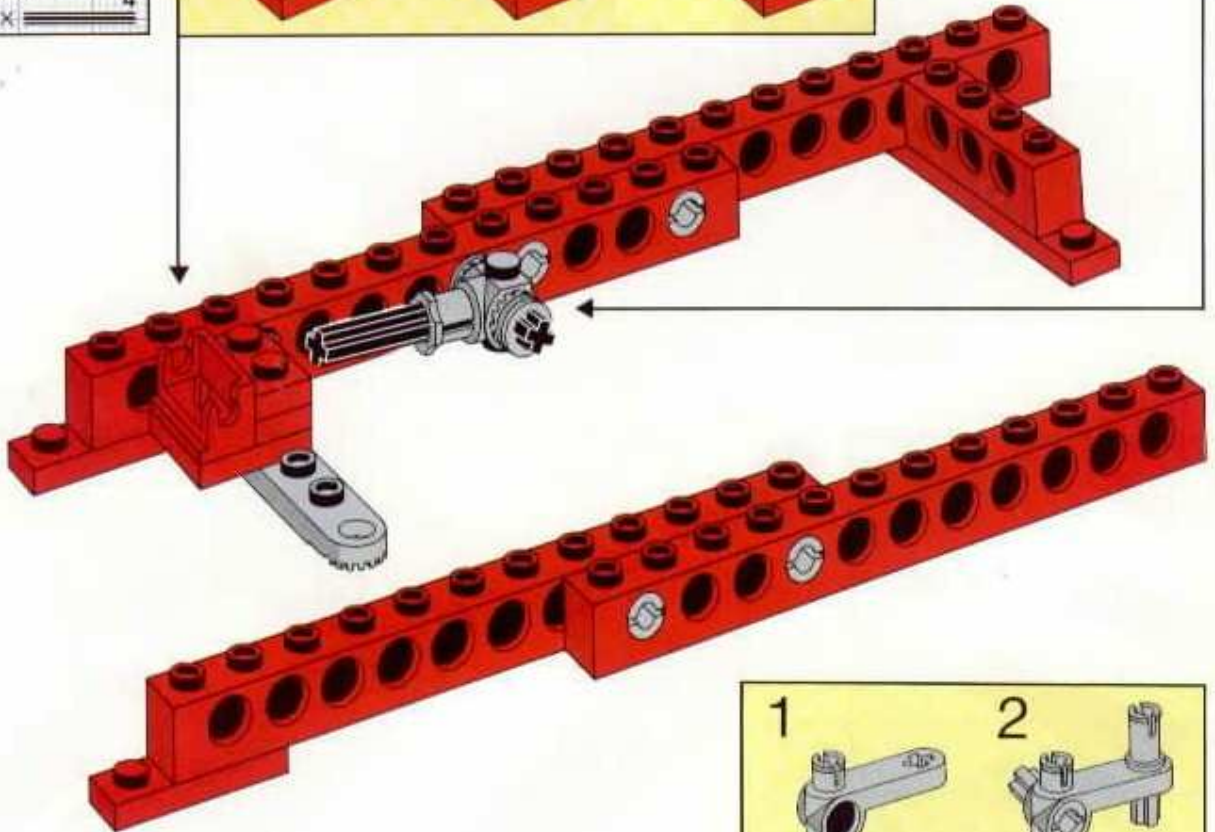
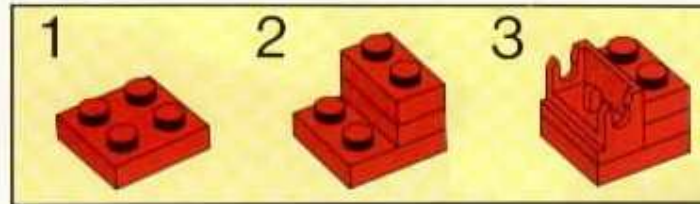
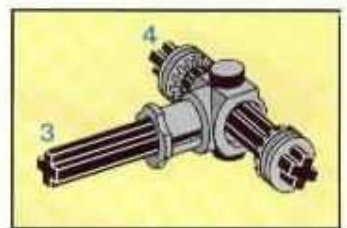

4

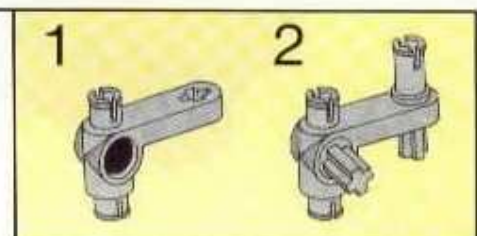
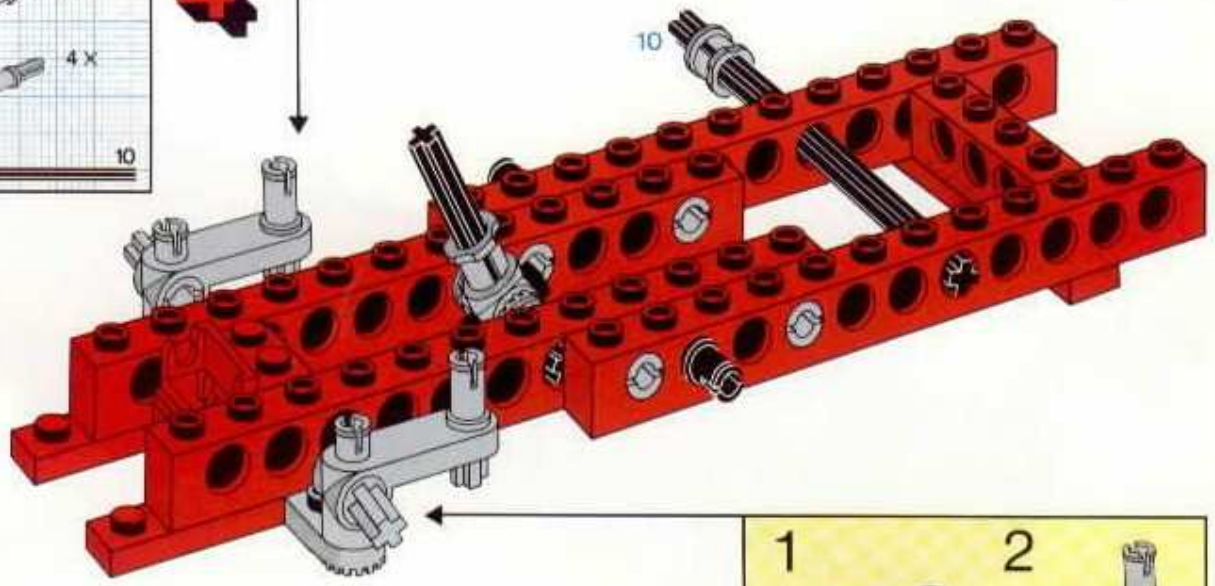

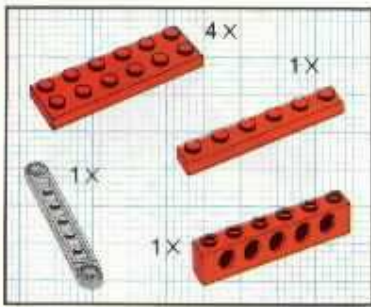

5

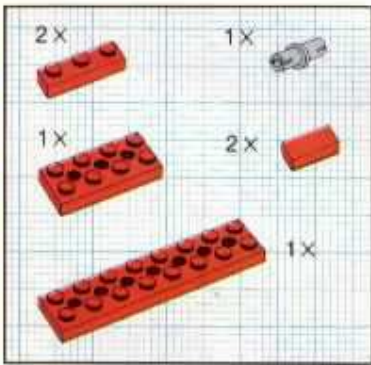
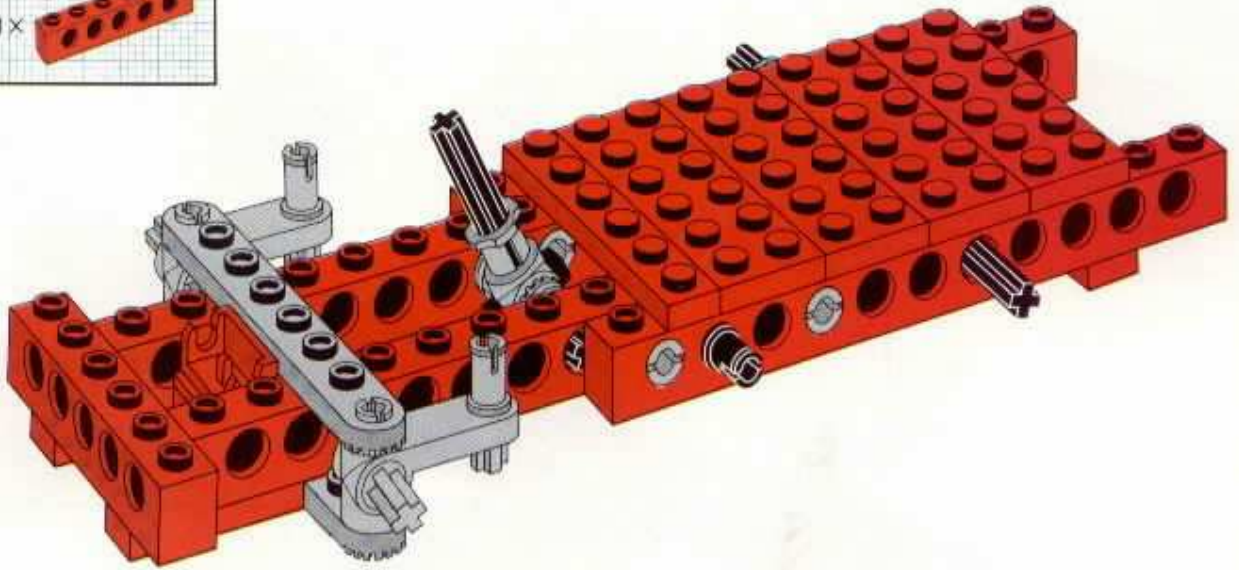

6

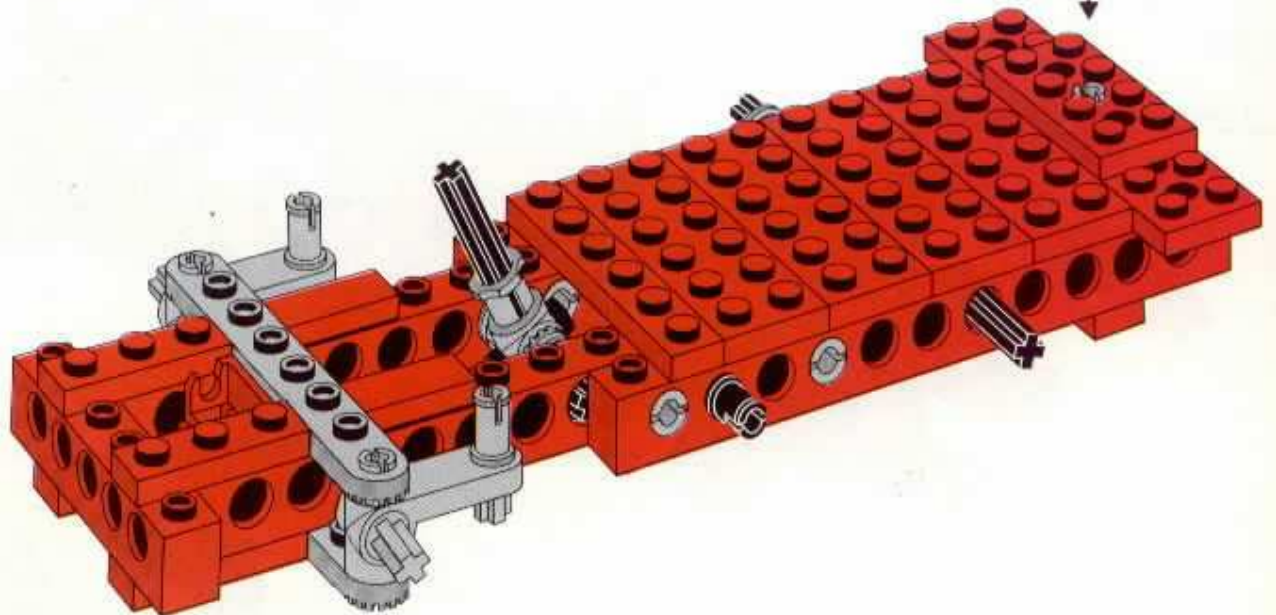
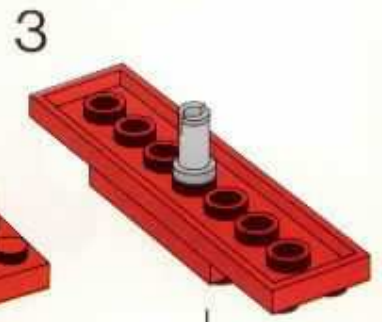
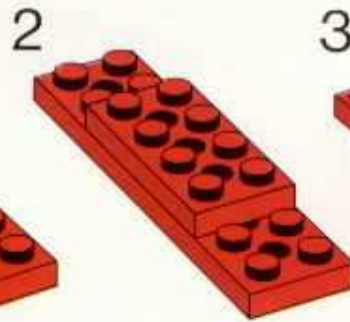
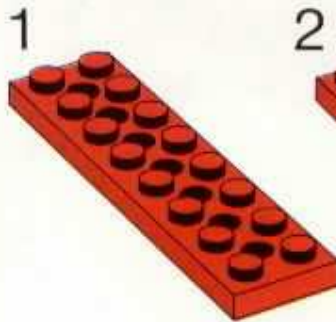

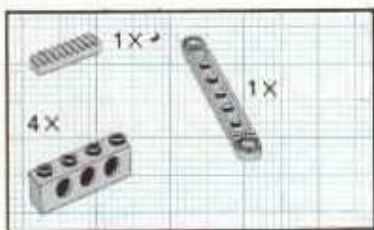

7

1

2

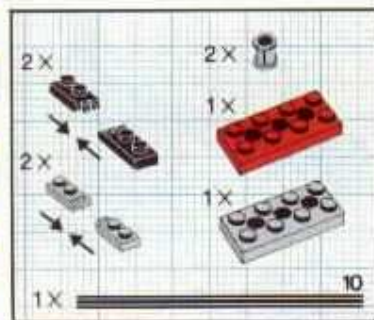
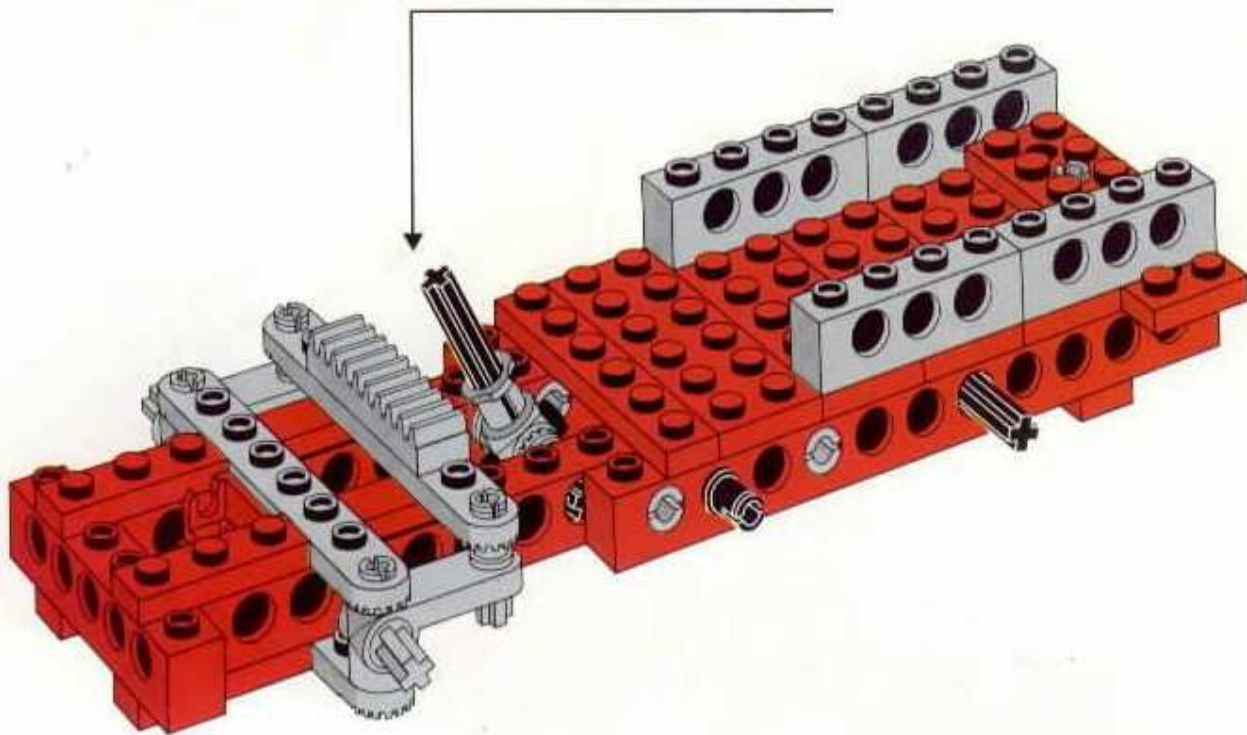
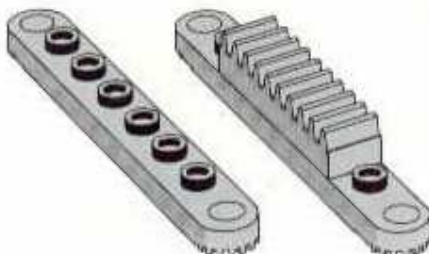

8

1

2

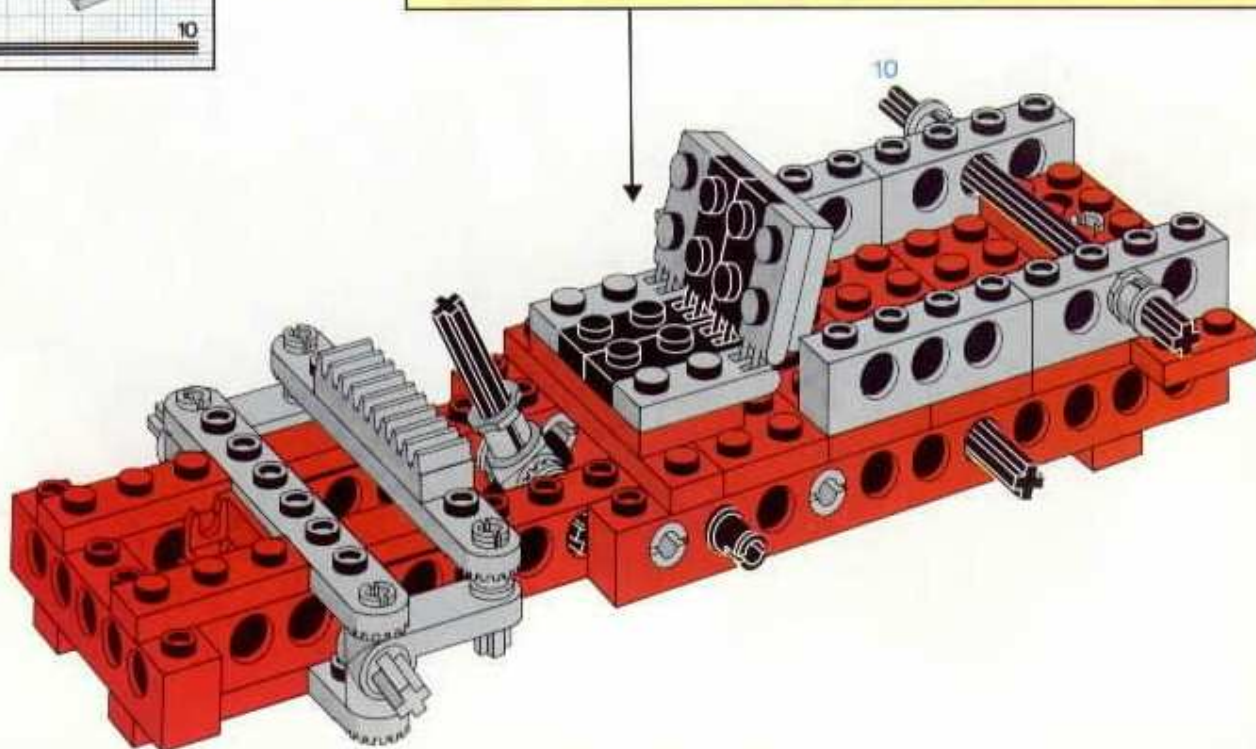
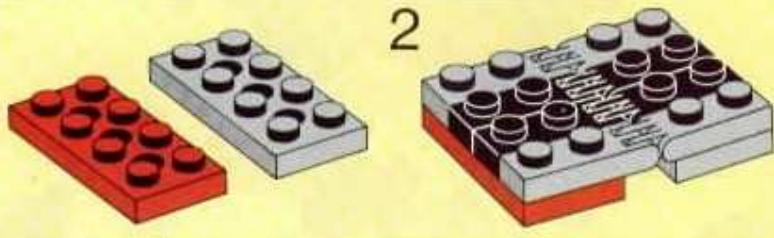



9

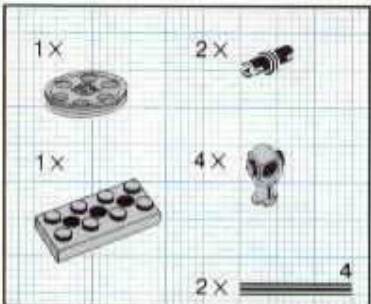
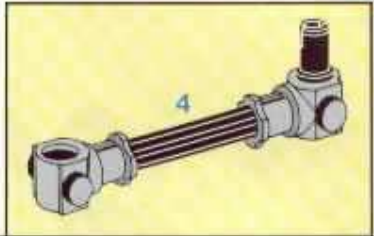
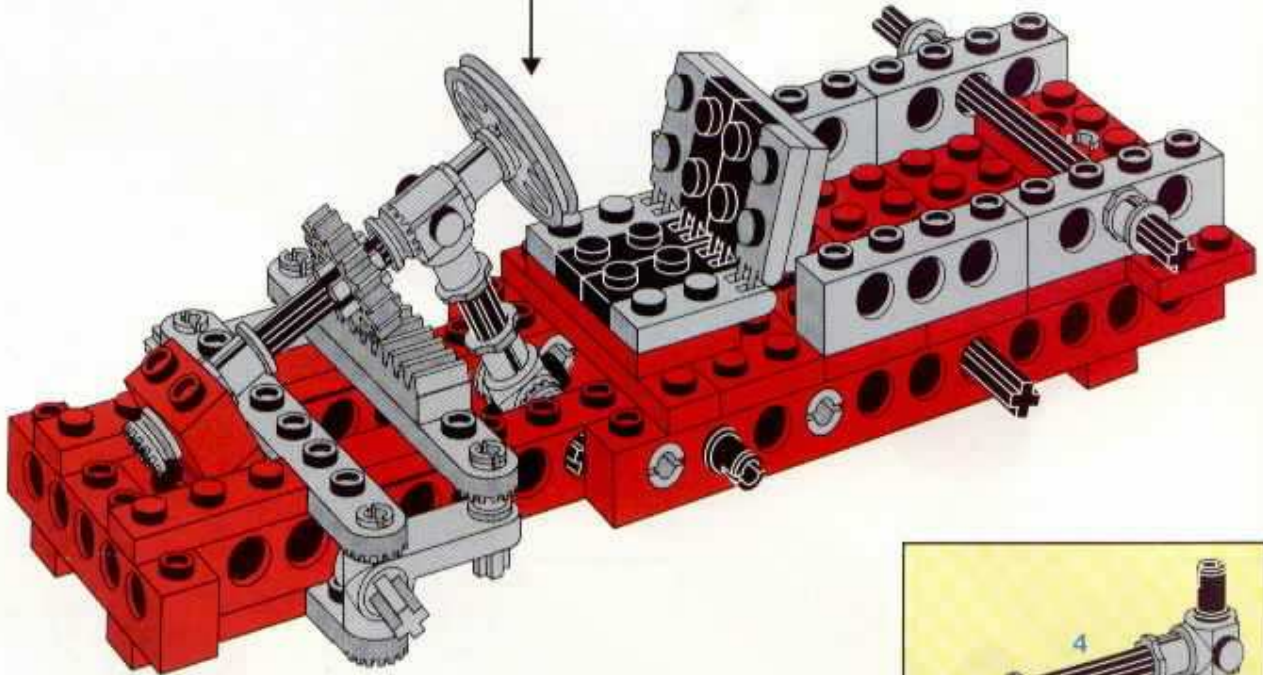
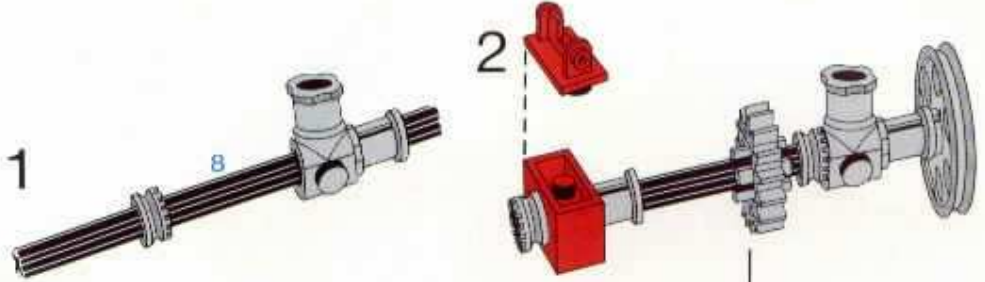

10

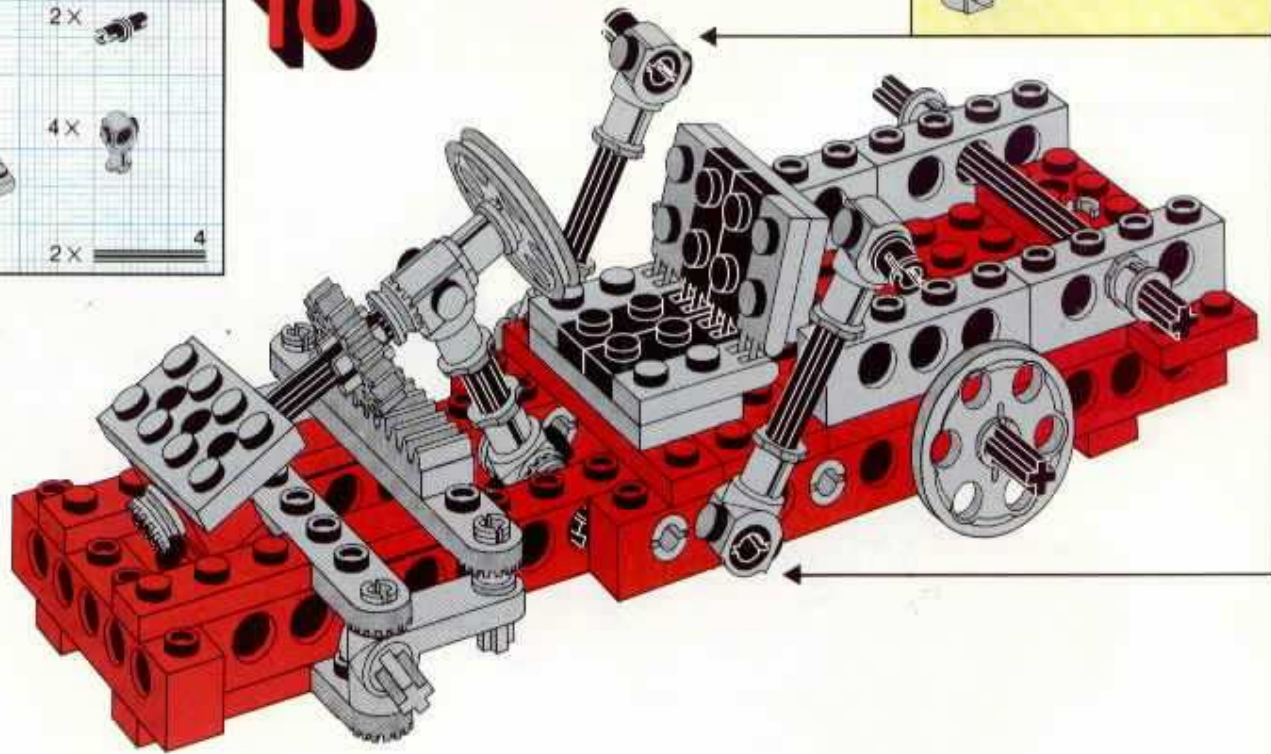

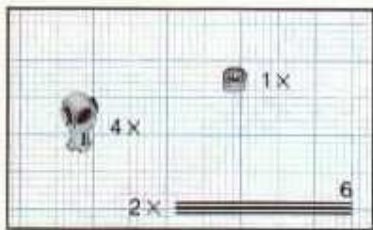

11

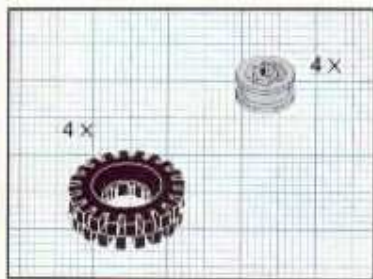

12



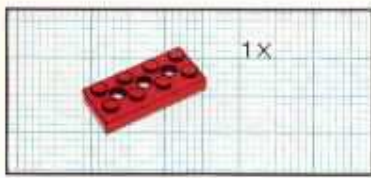

1

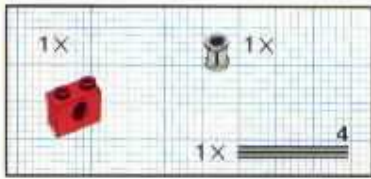

2

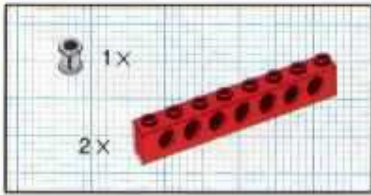
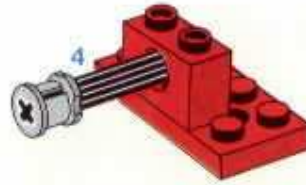

3

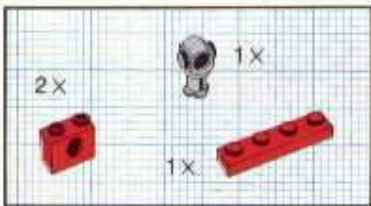
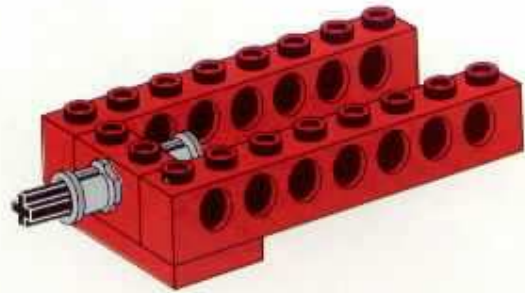

4

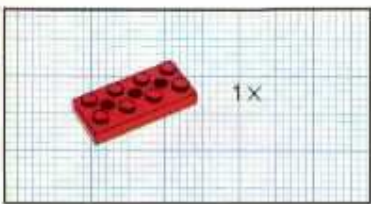
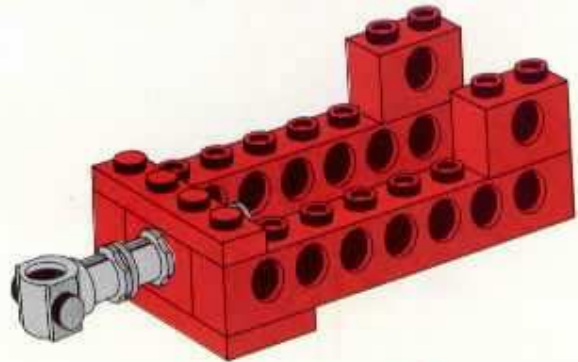

5

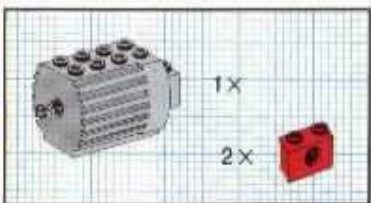
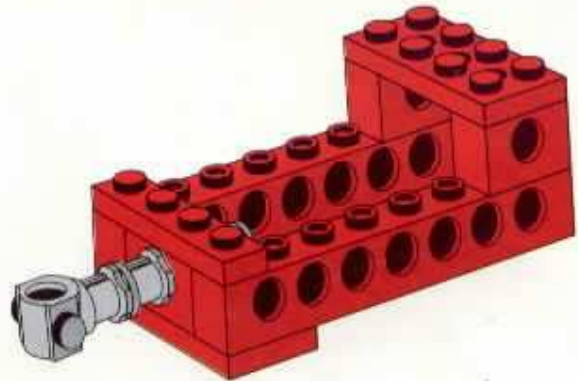

6

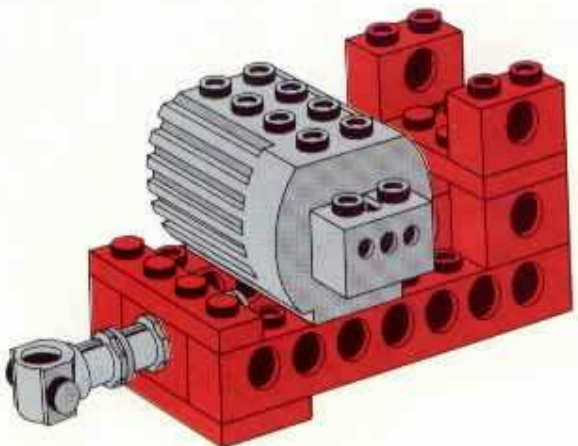

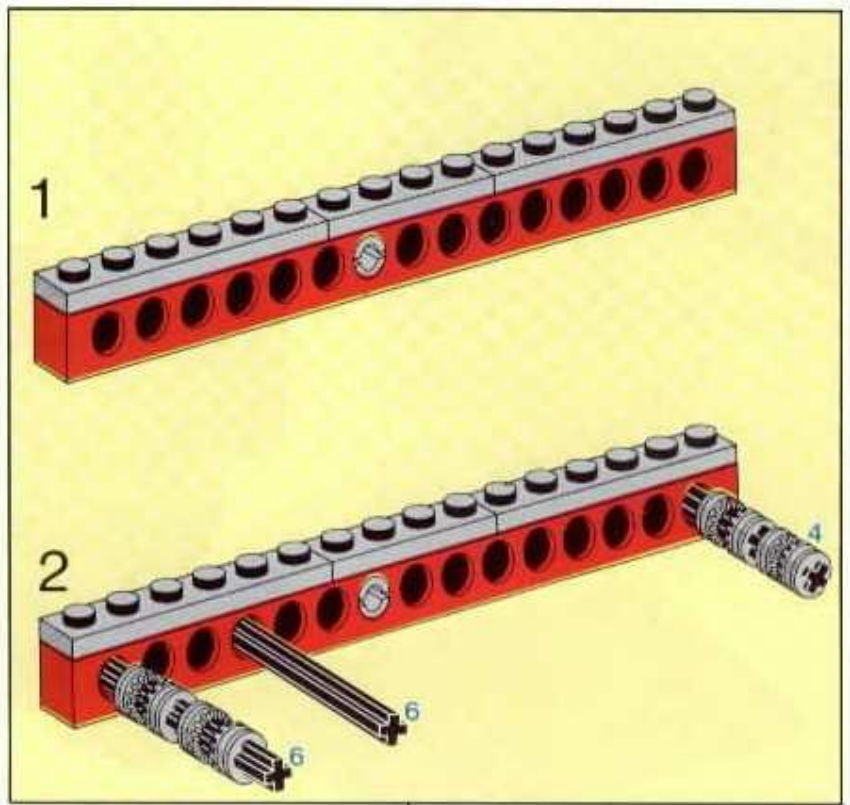
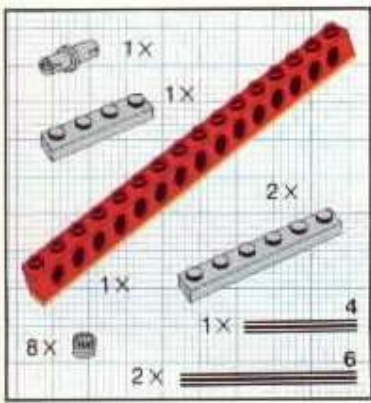

7

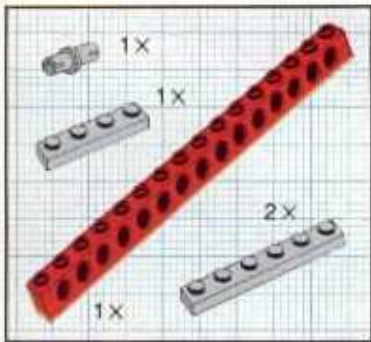
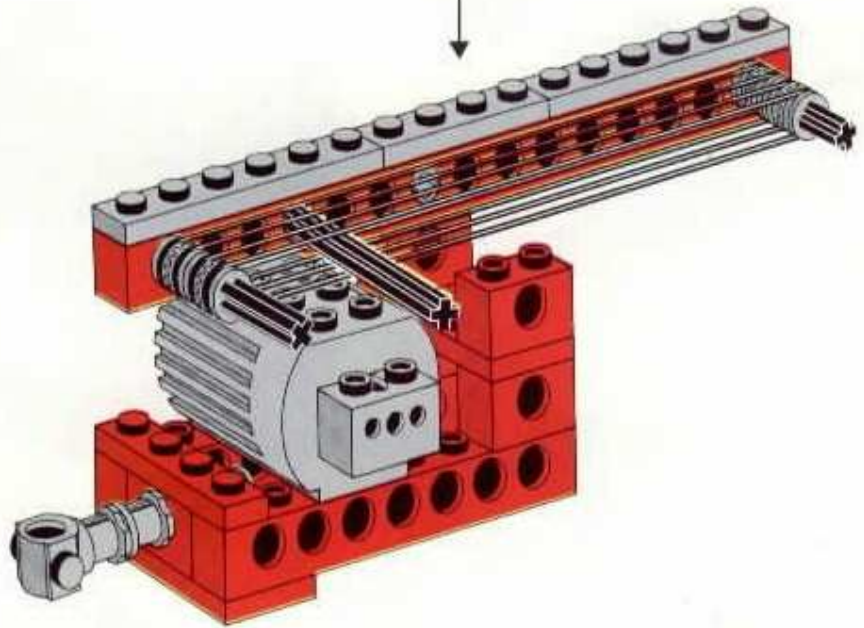

8

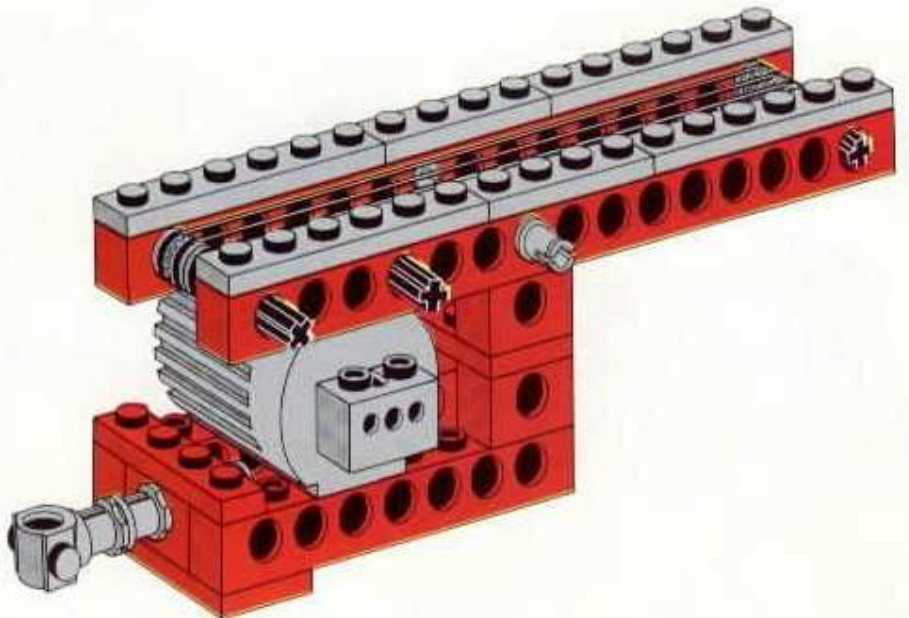

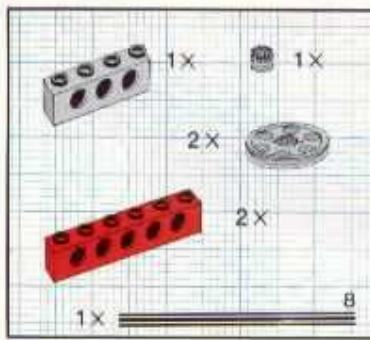

9

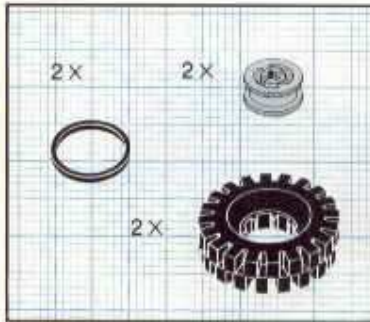
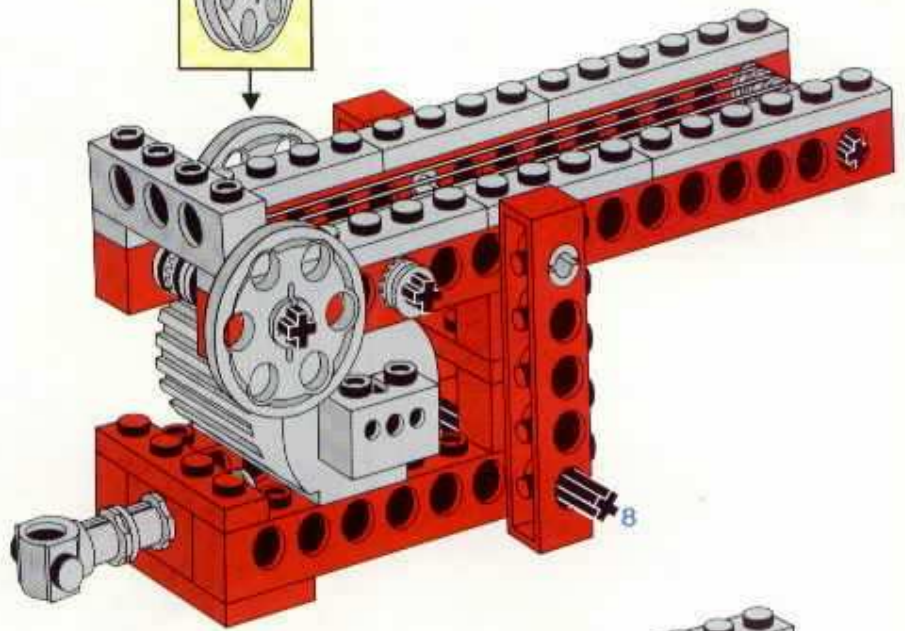

10

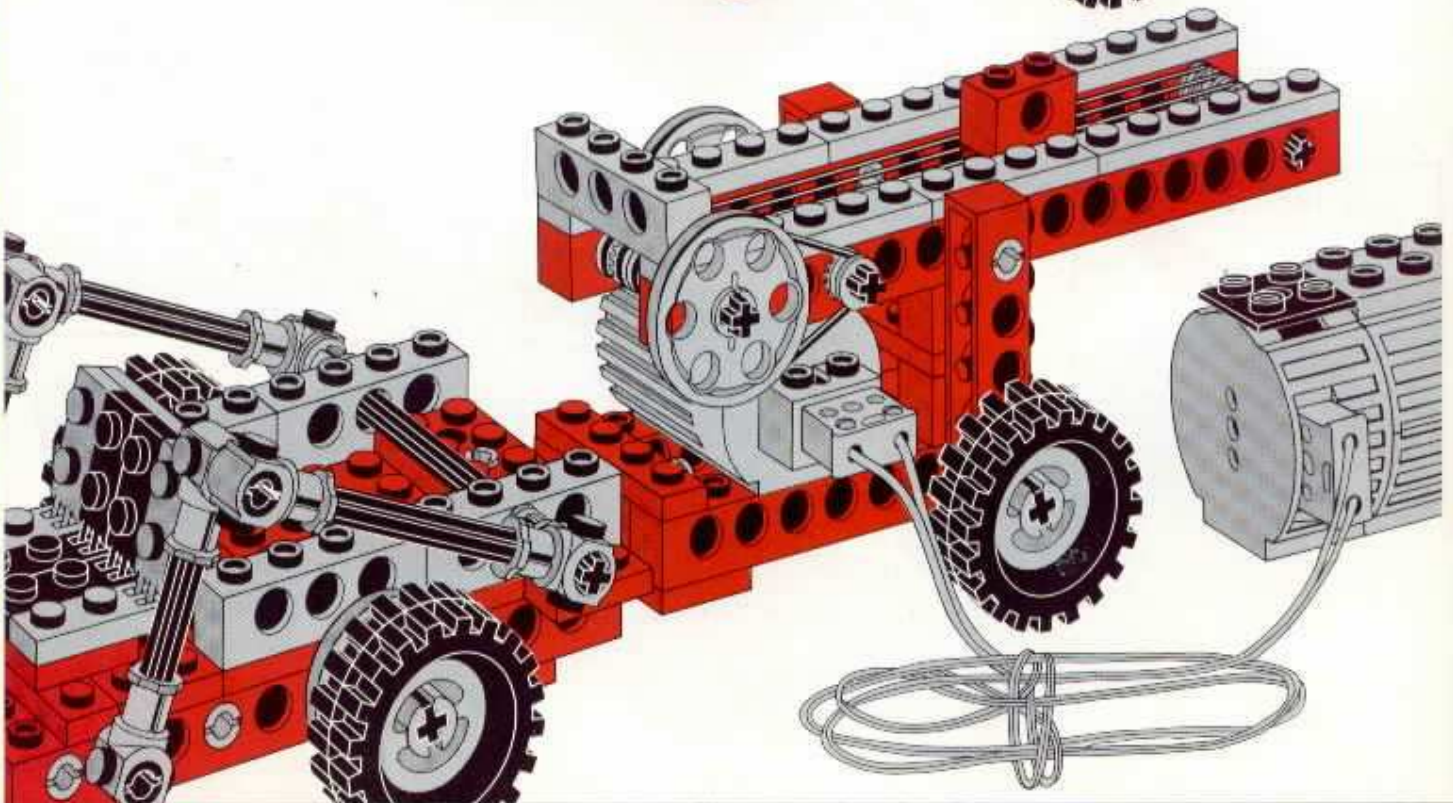
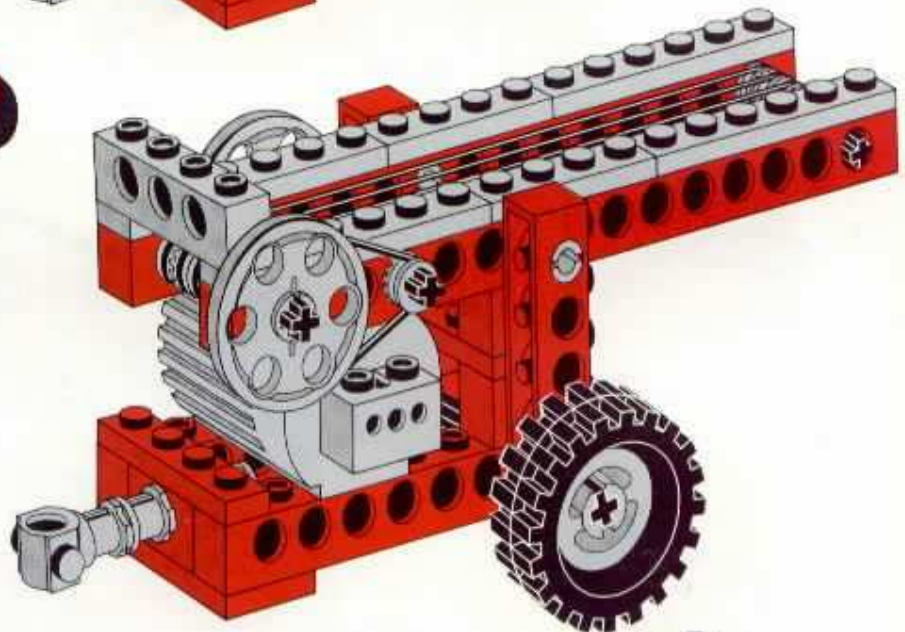

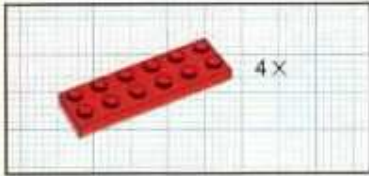

1

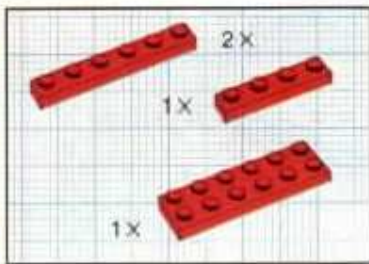
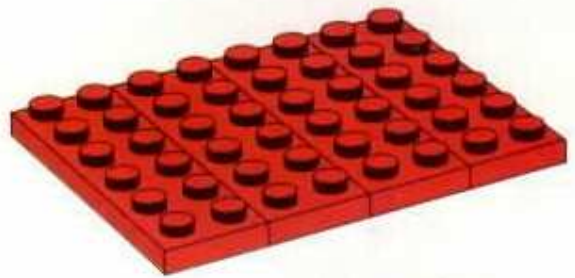

2

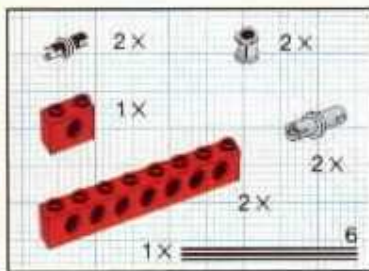

3

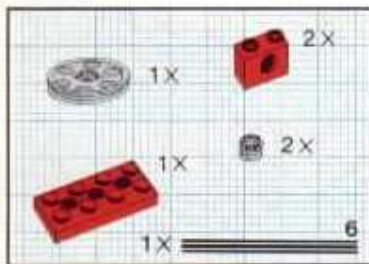
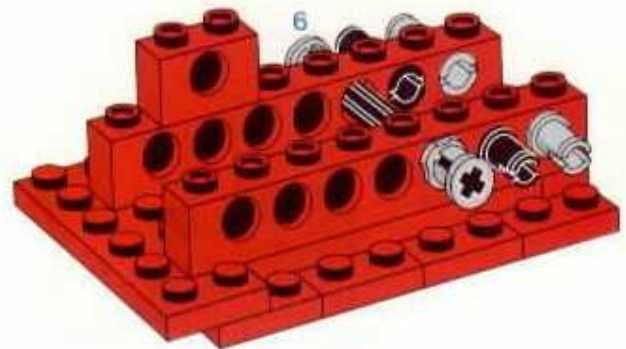

4

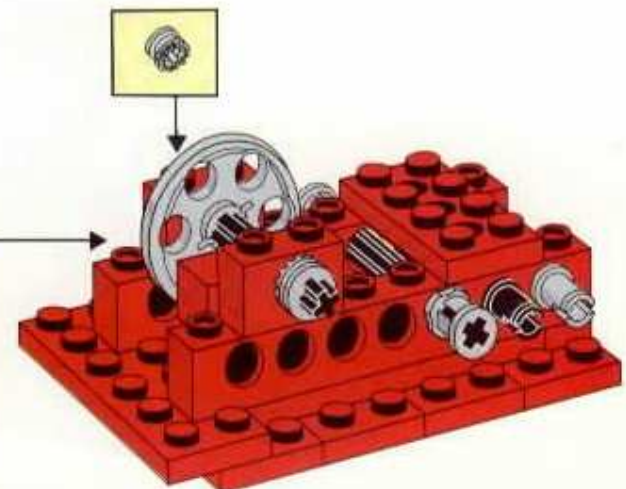
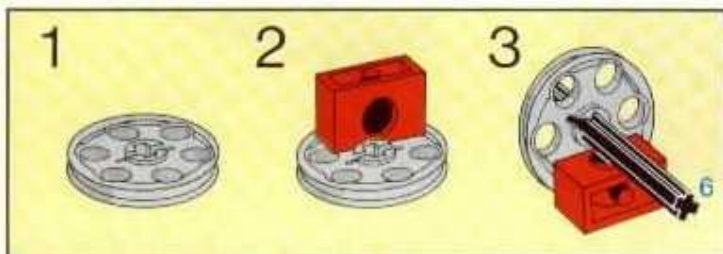

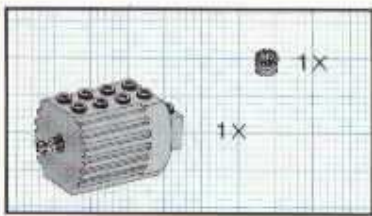

5

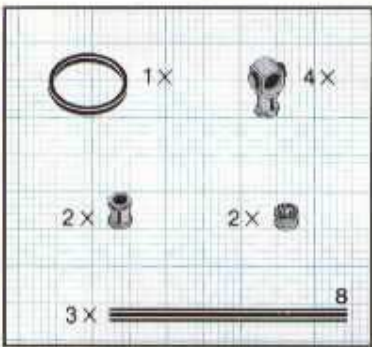
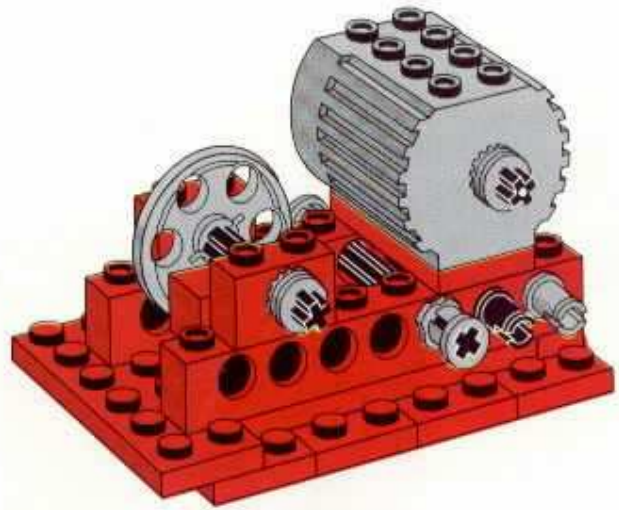

6

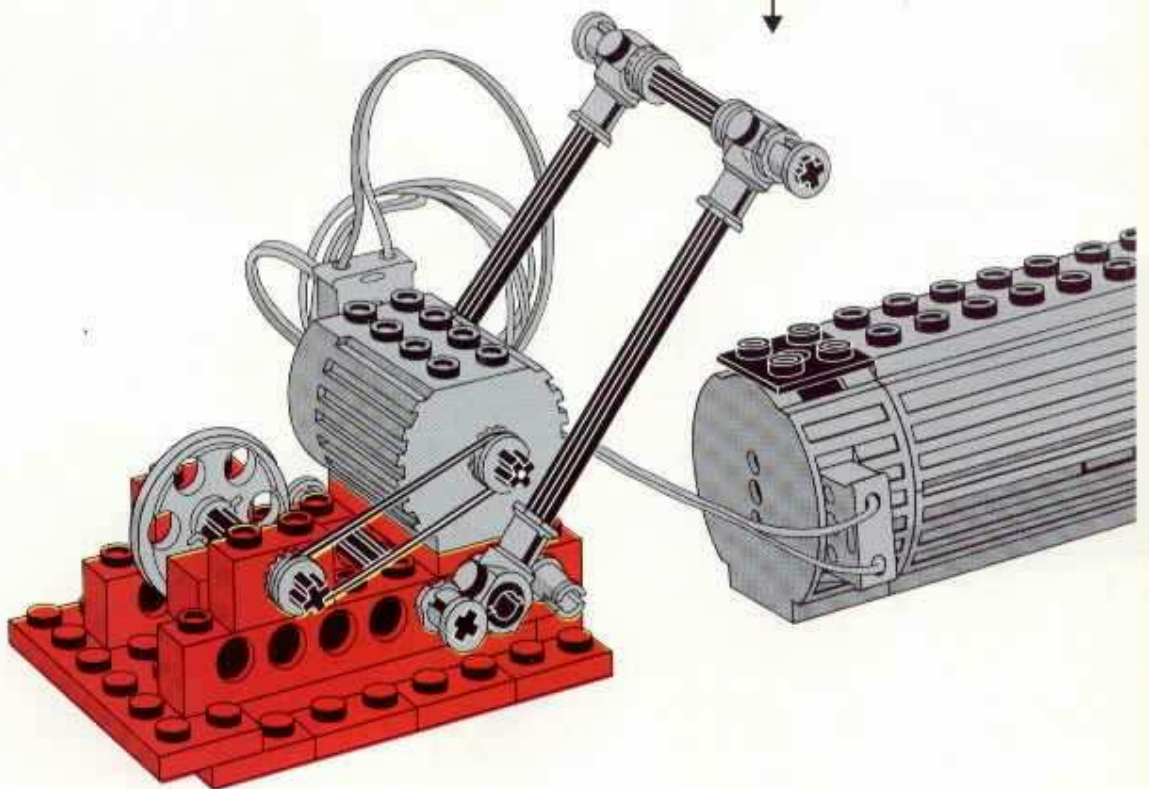
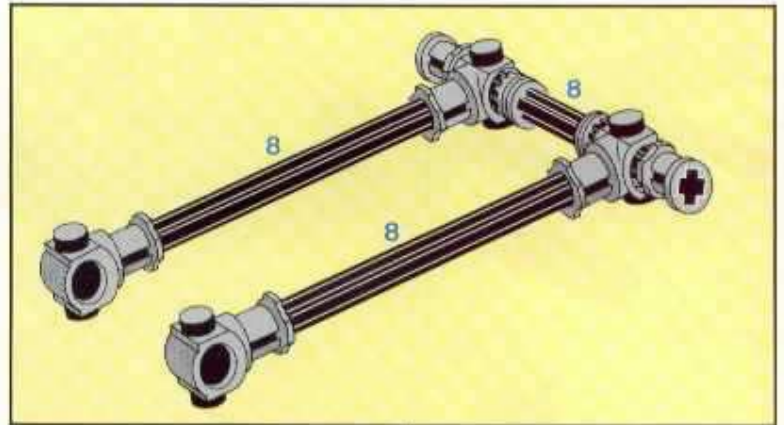



1

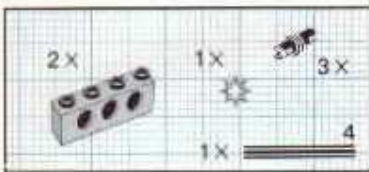

2

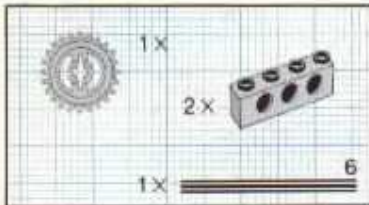
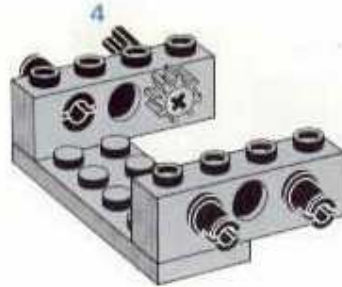

3

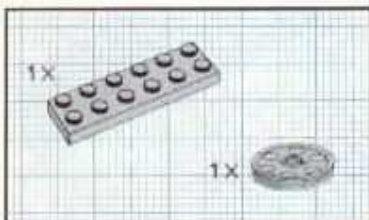
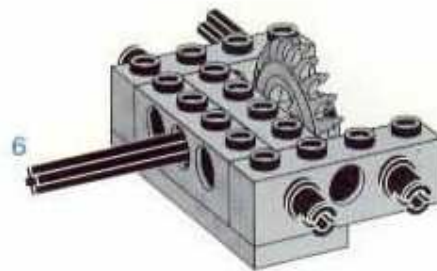

4

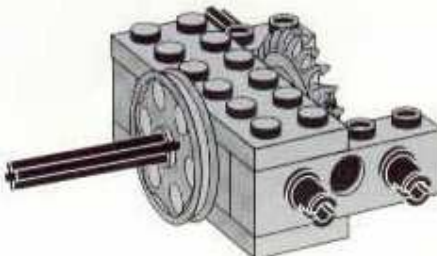

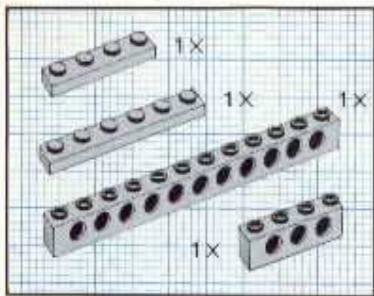

5

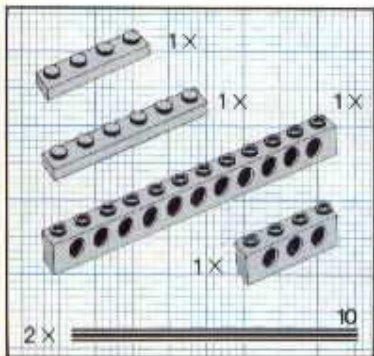
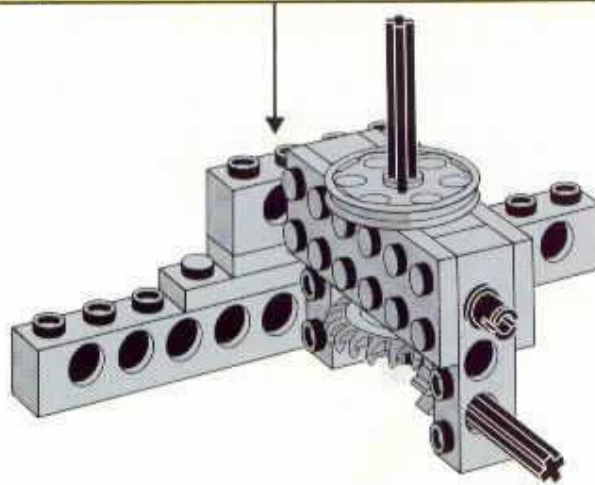
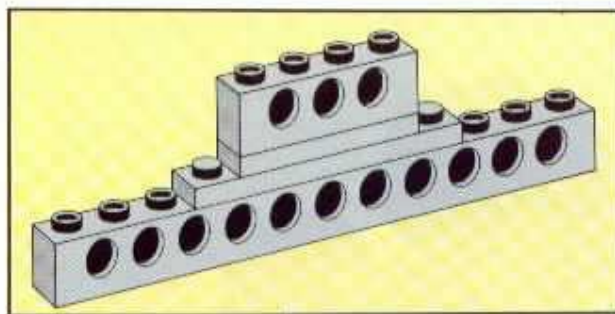

6

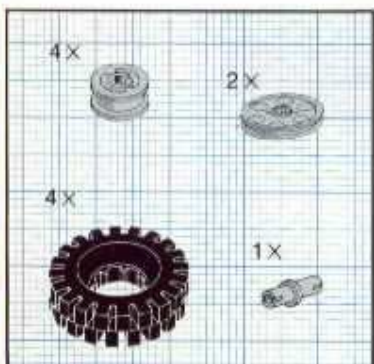
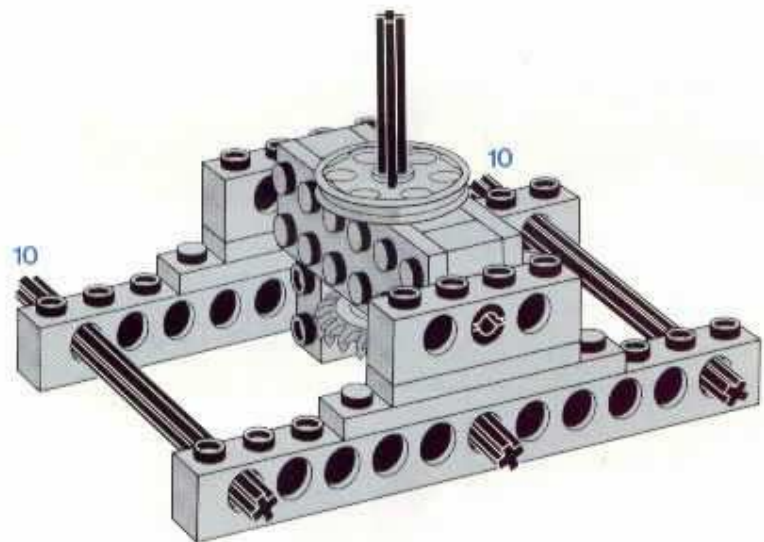

7

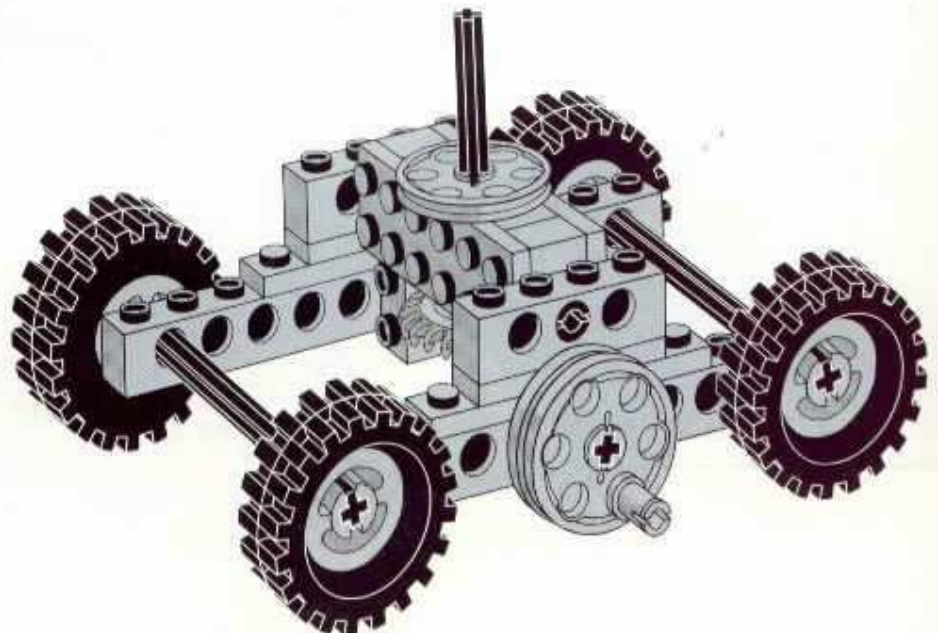

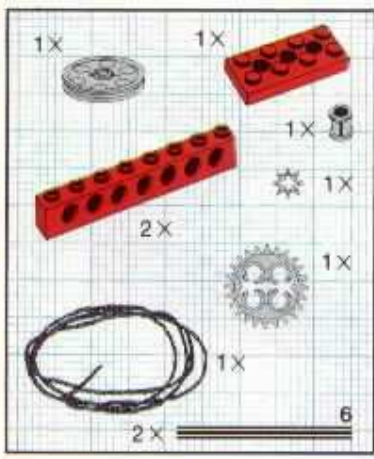

11



12

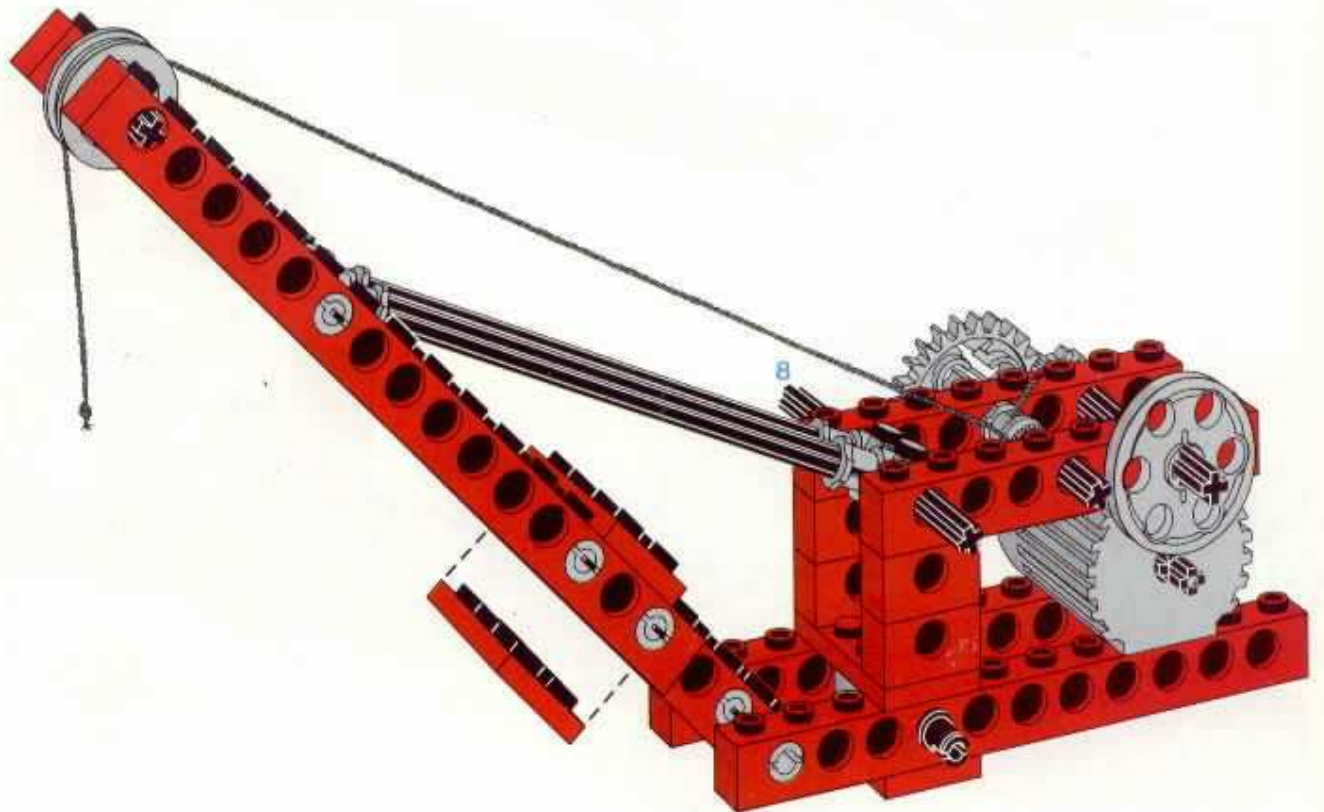

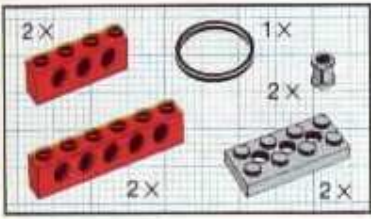

13

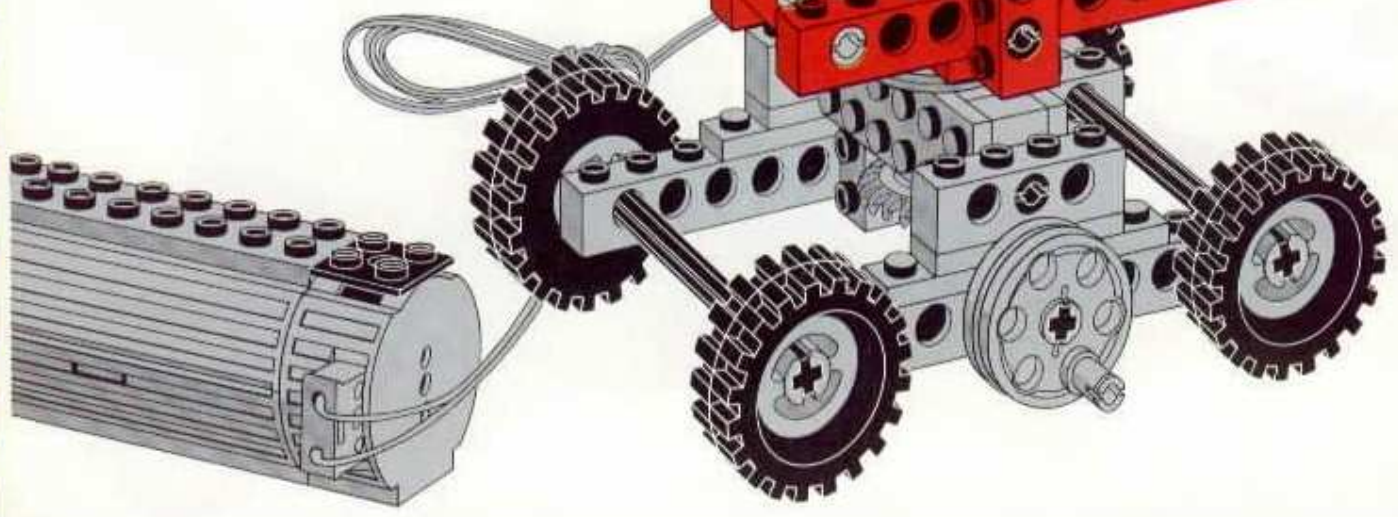
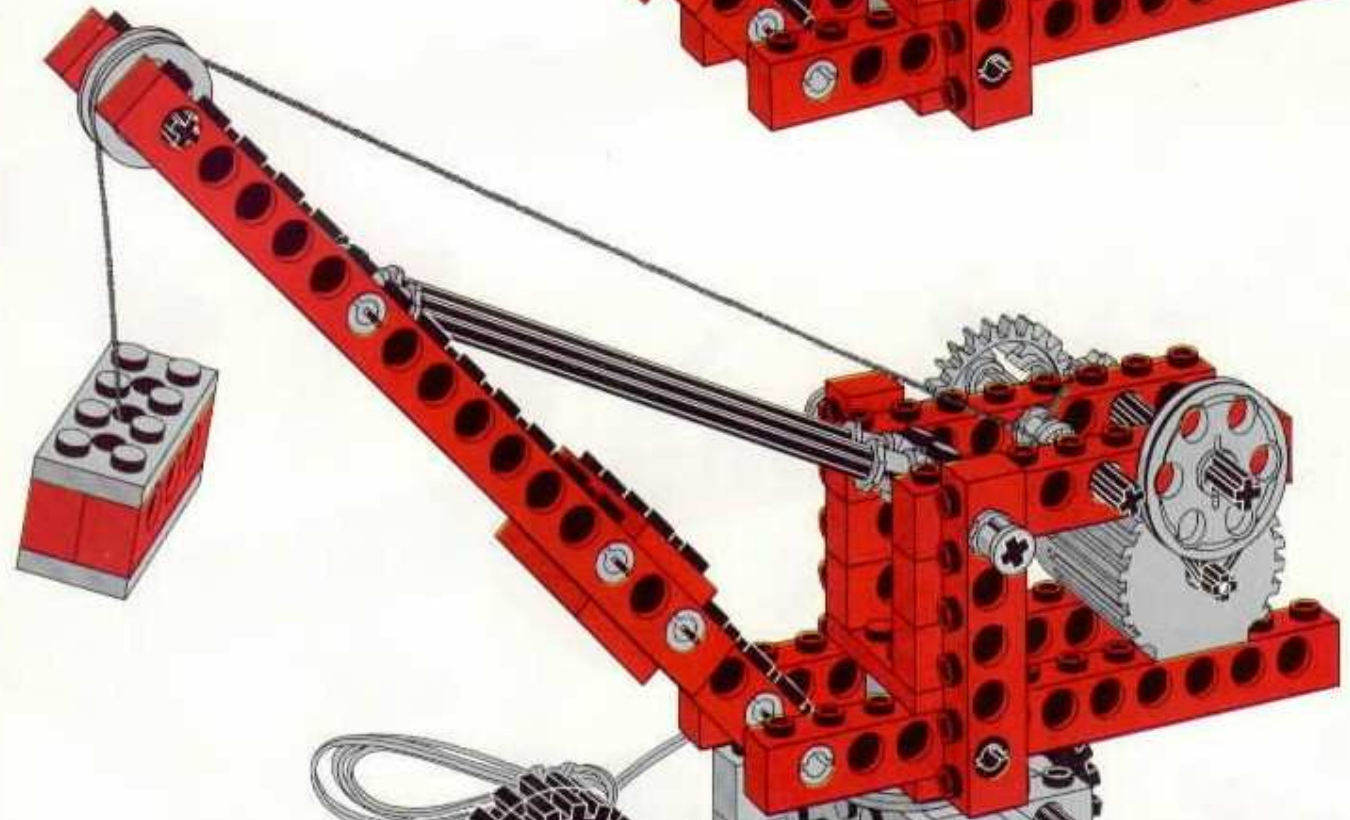
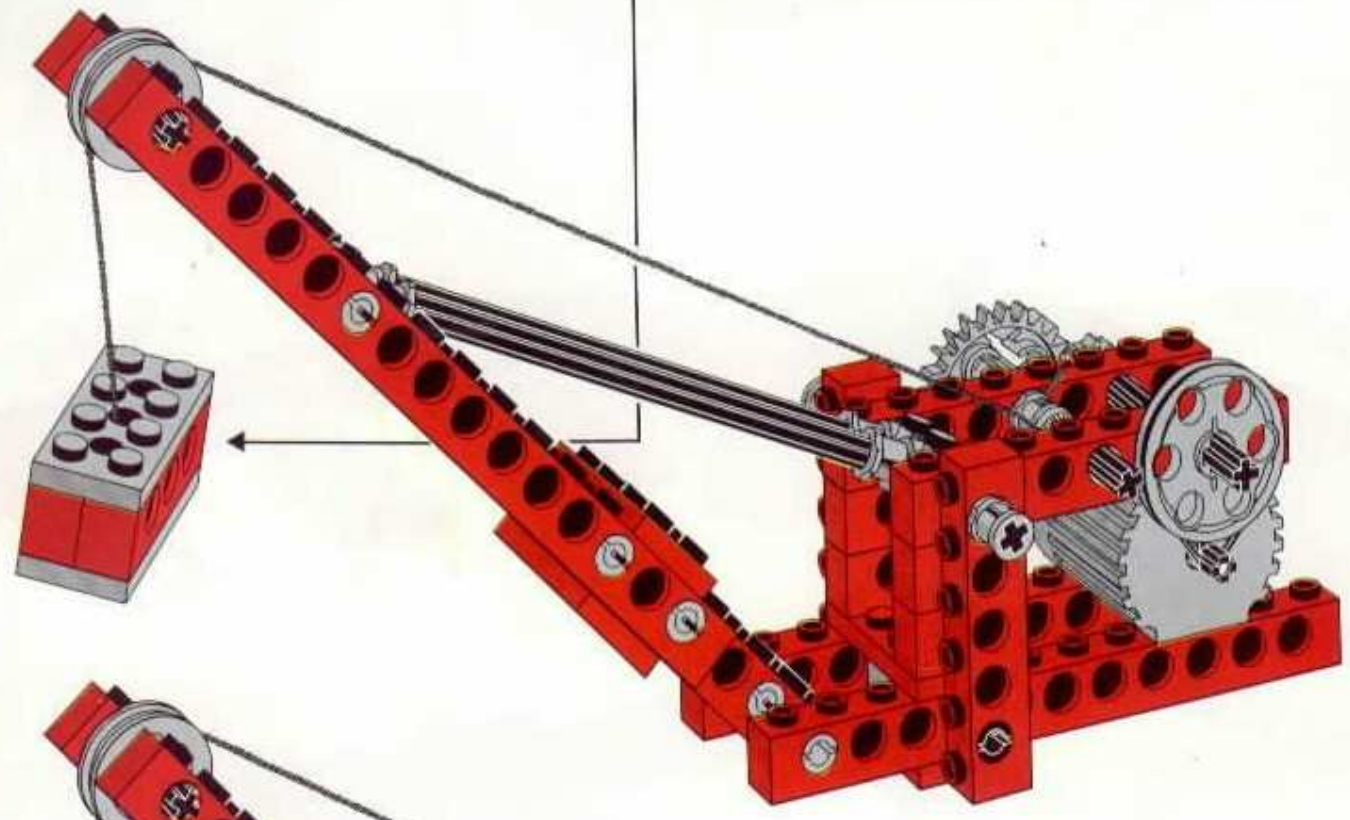
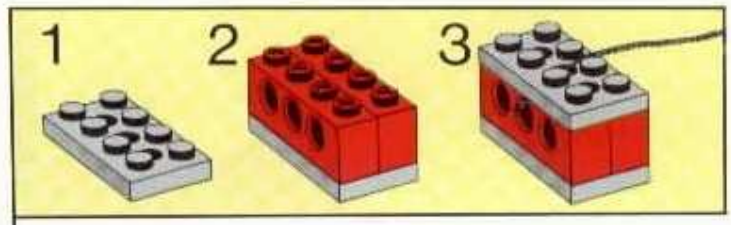

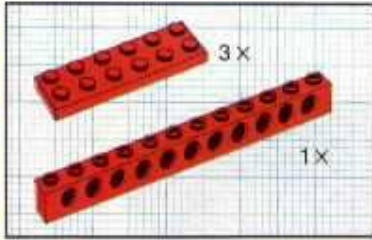
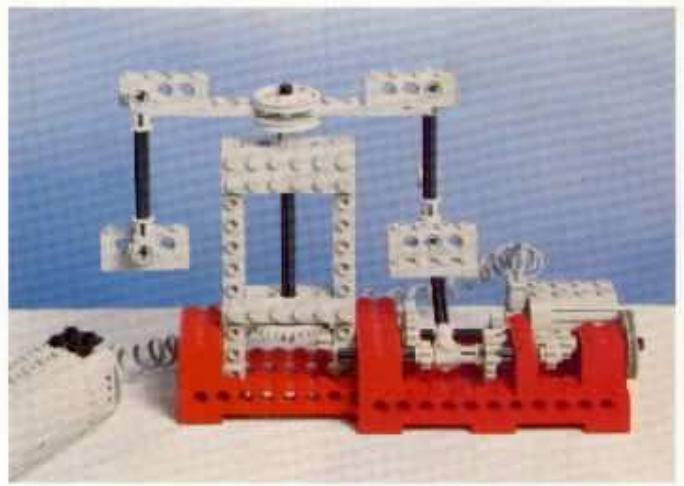

1

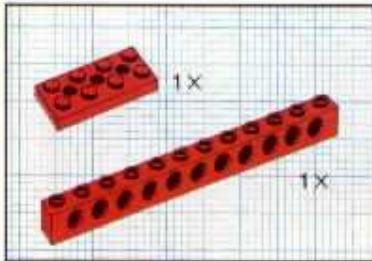
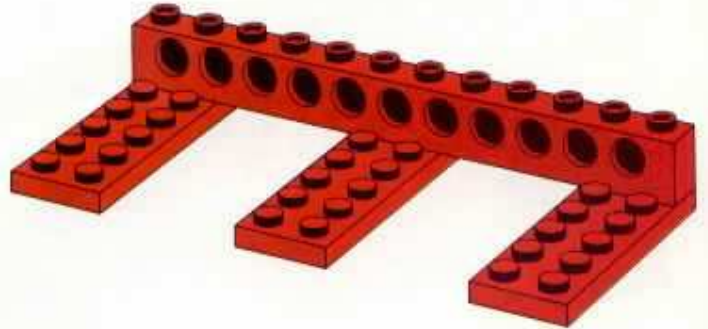

2

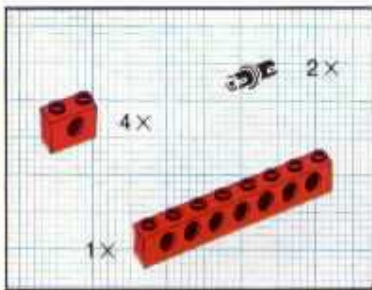
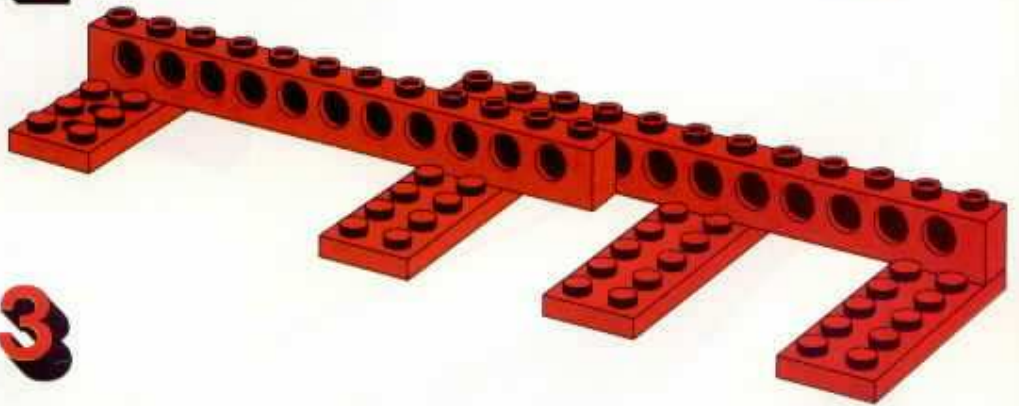

3

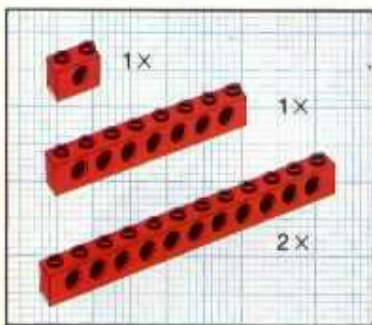

4



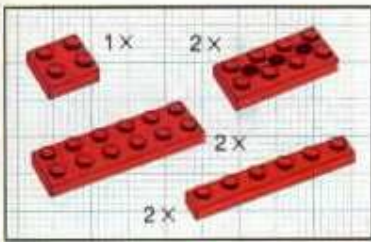

5

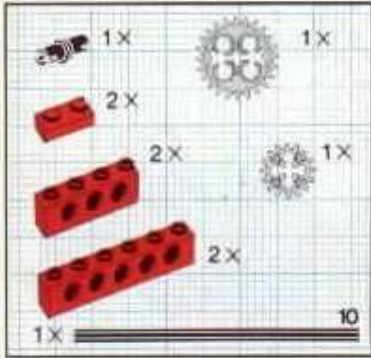
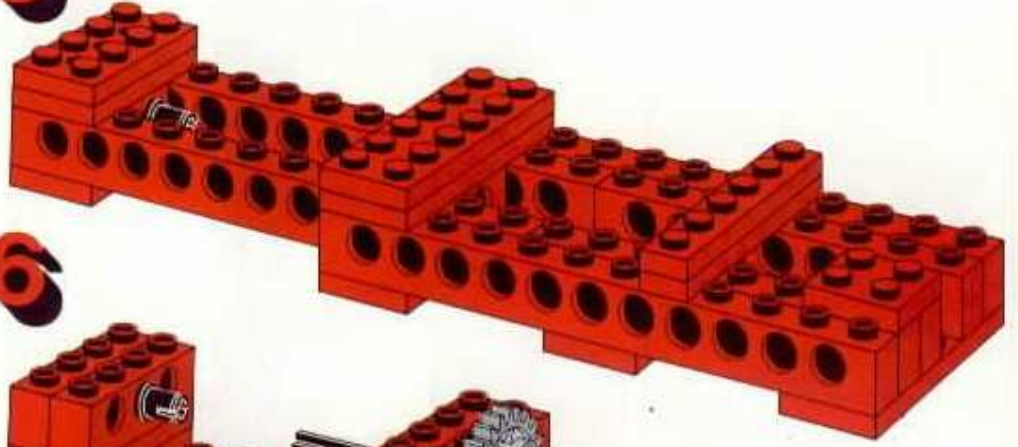

6

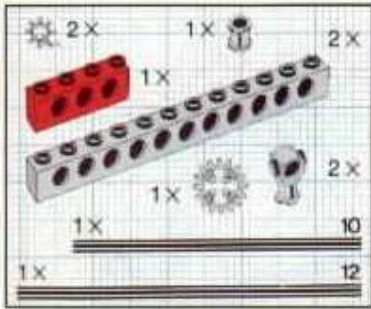
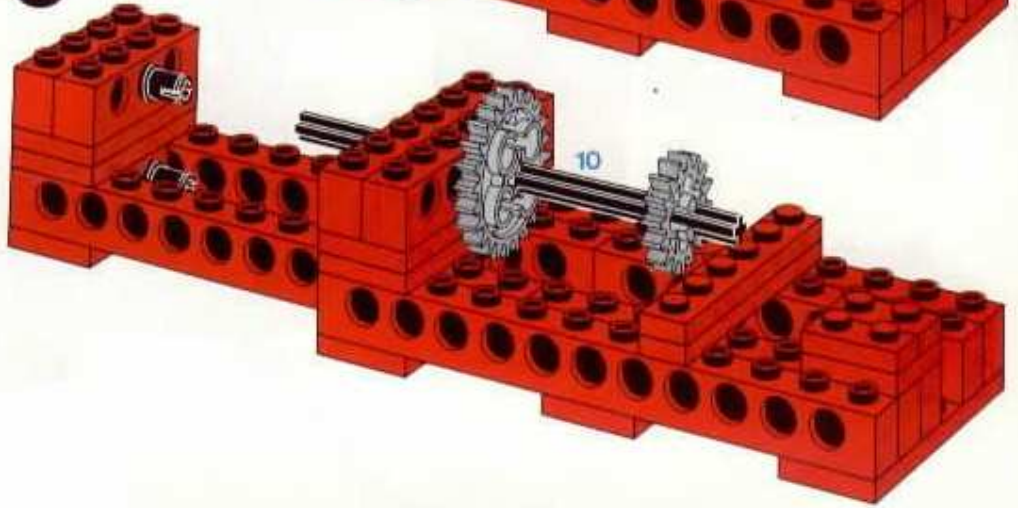

7

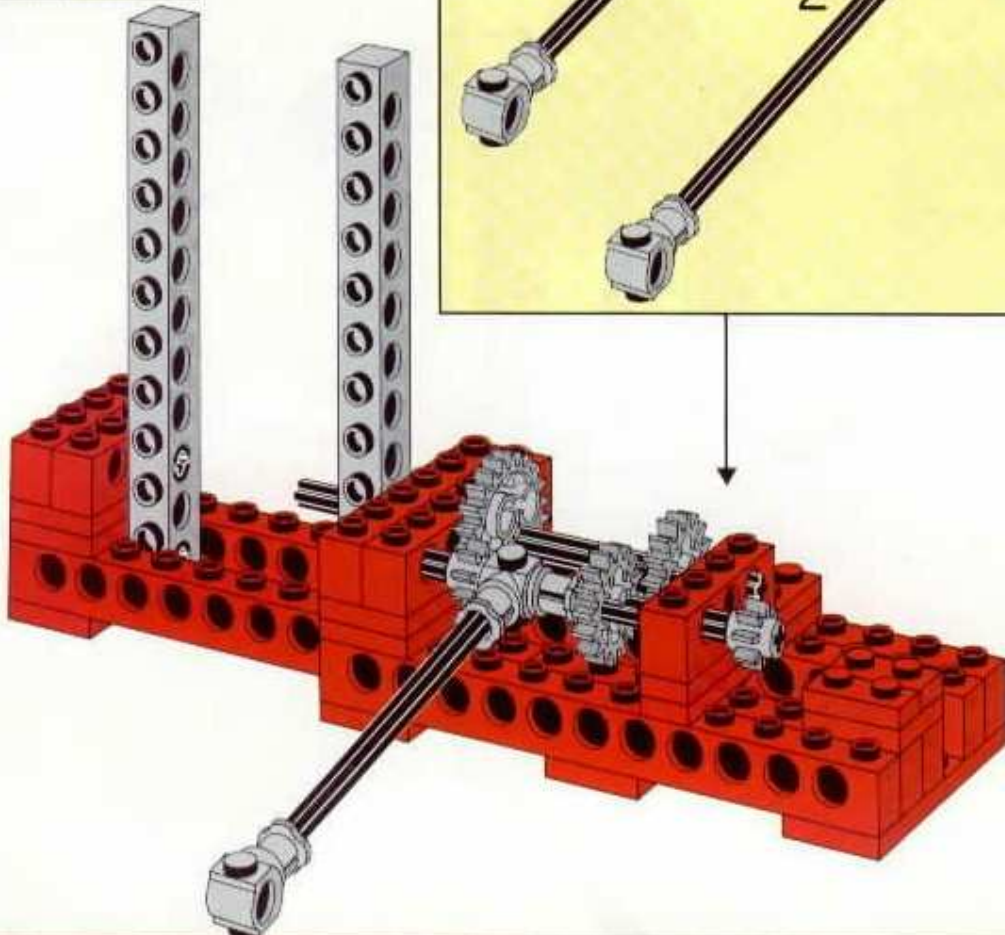
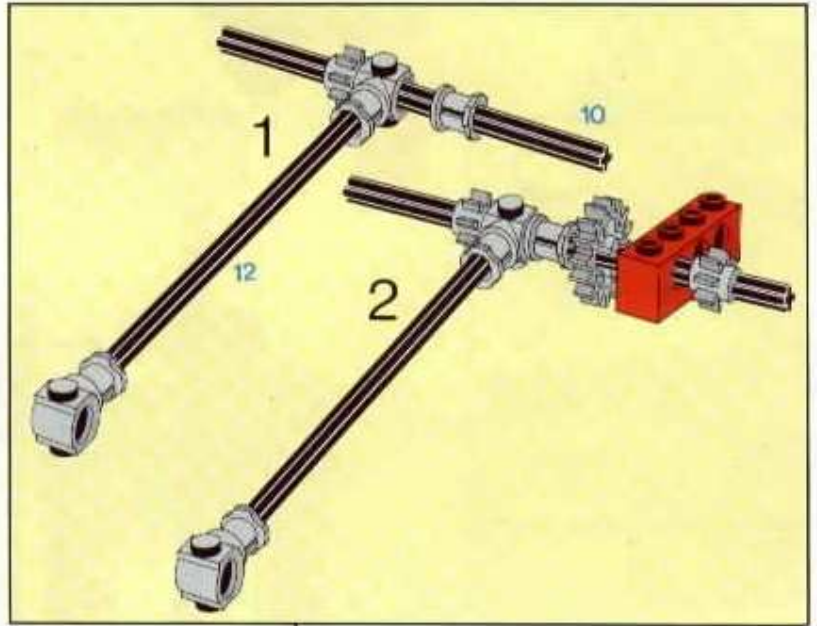

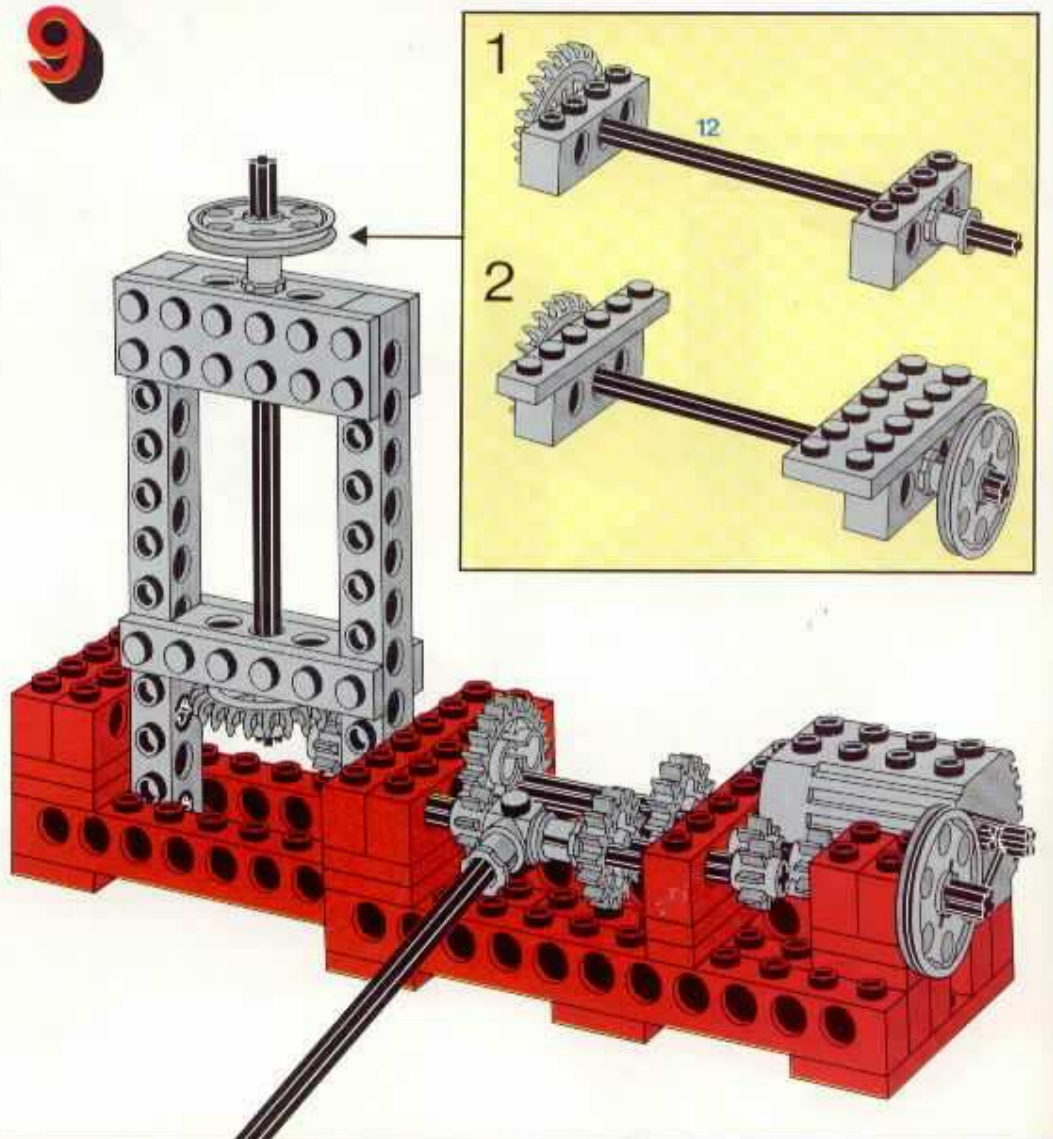
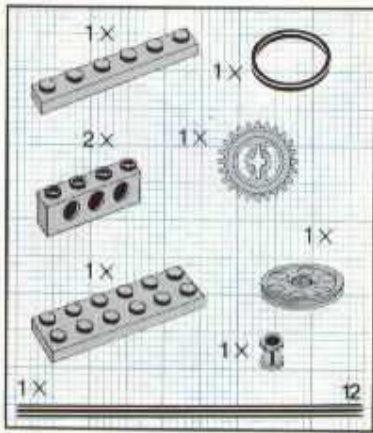
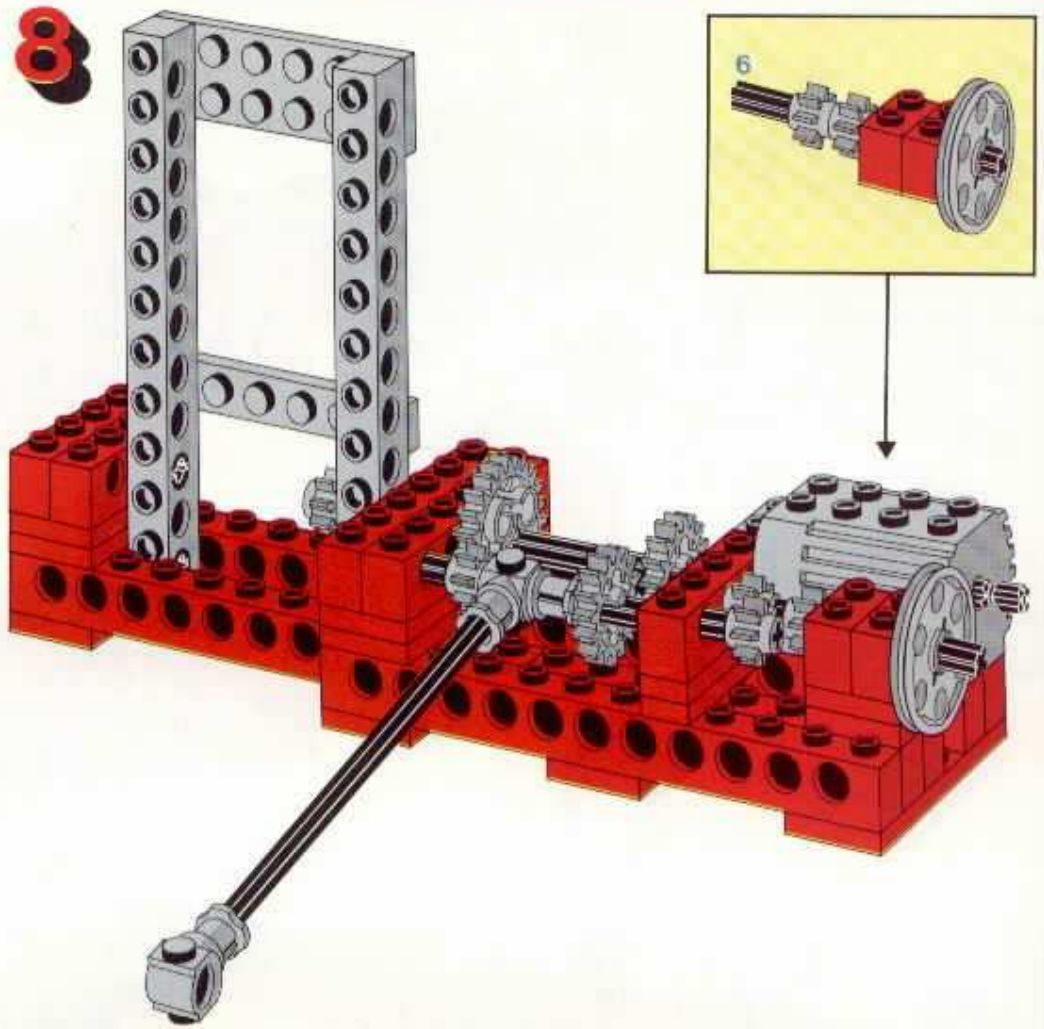
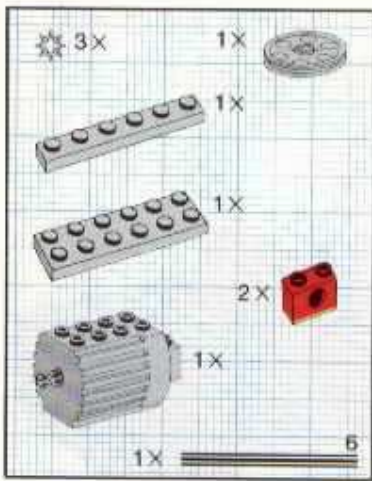

10

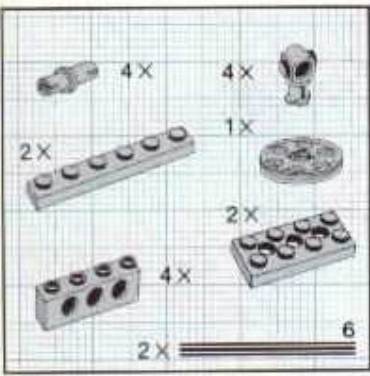

1



2

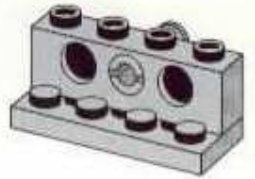
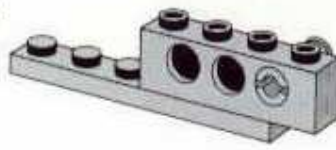

3

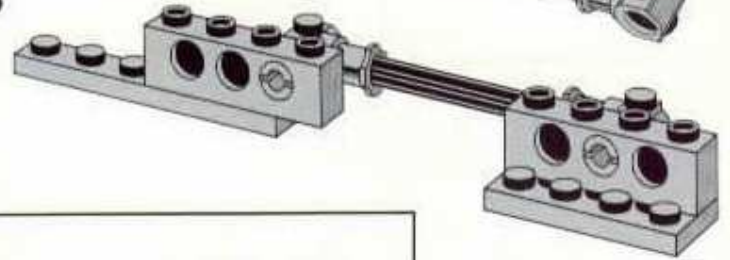

2x

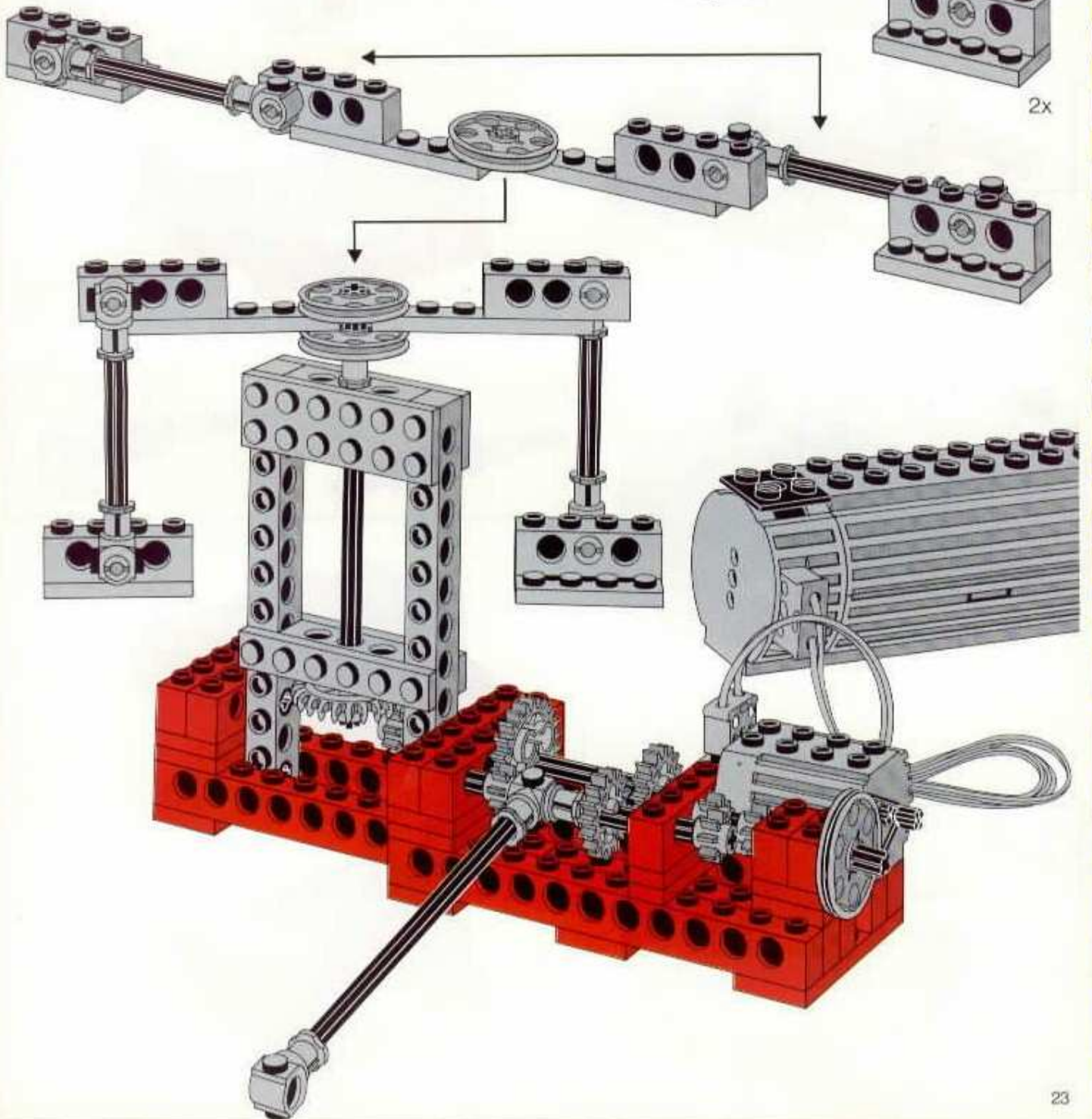

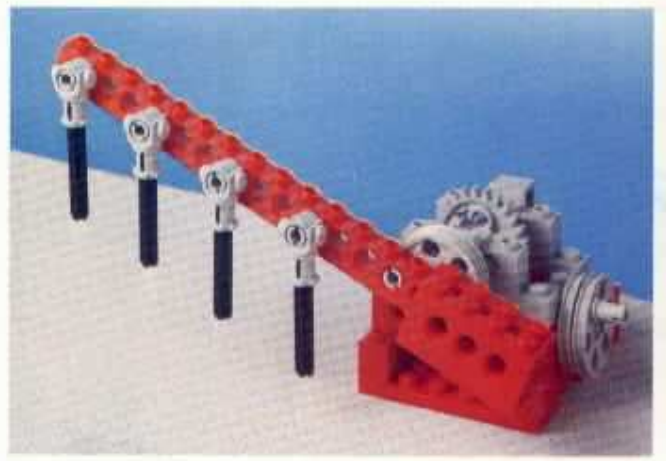

1

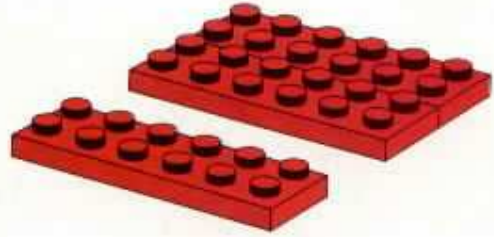

2

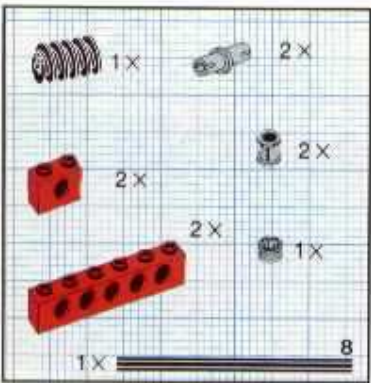
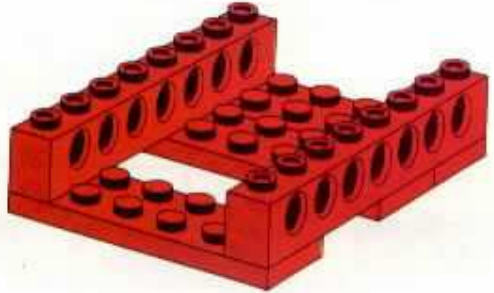

3

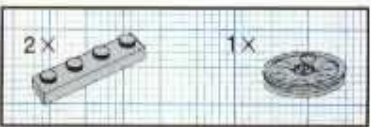
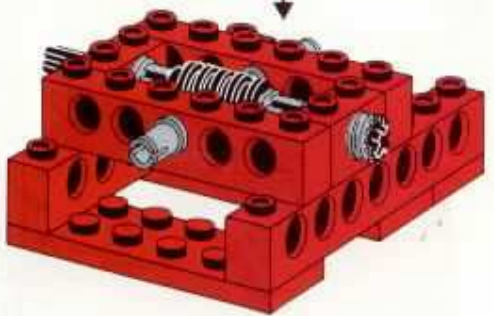
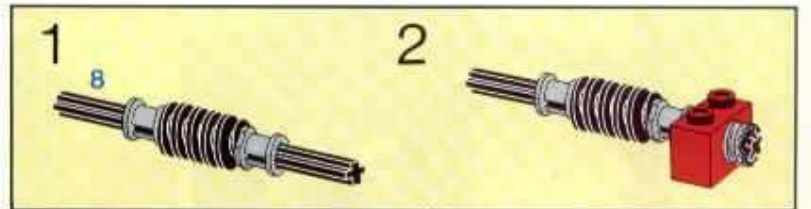

4

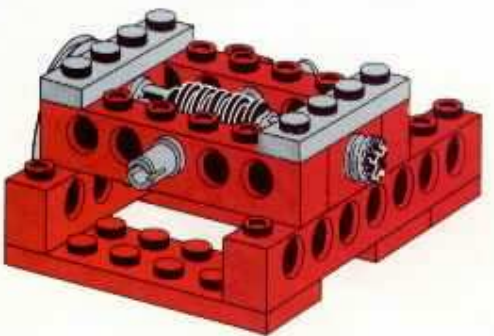

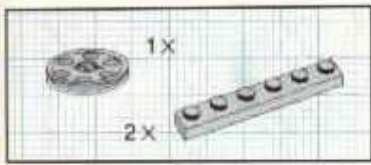

5

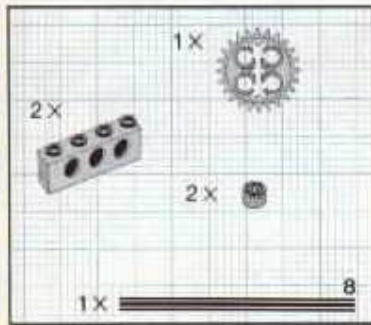
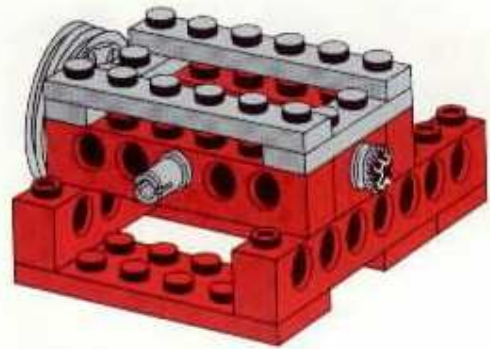

6

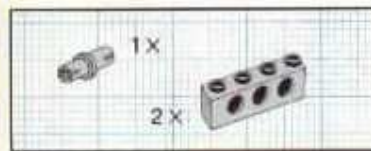
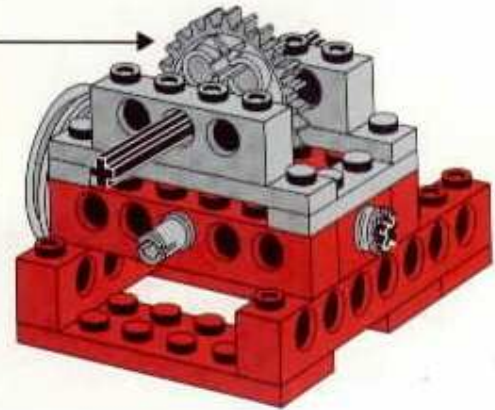

7

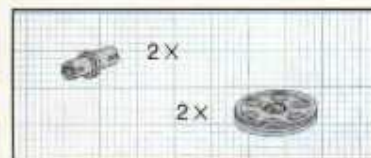
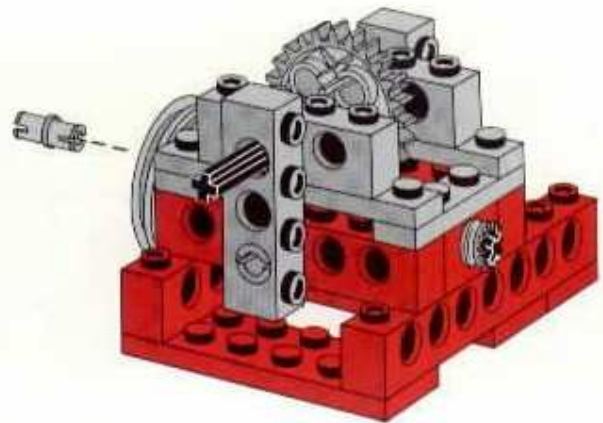

8

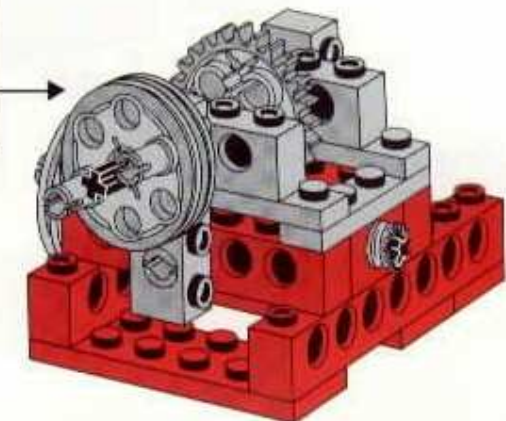
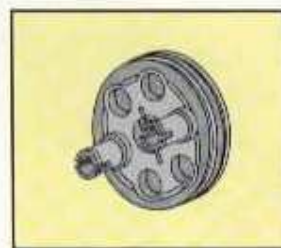

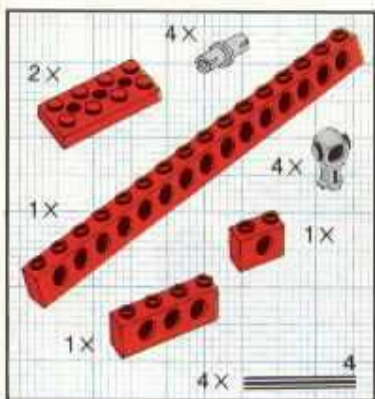

1

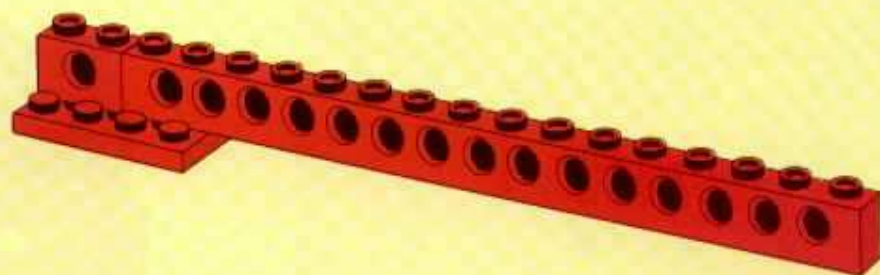

2

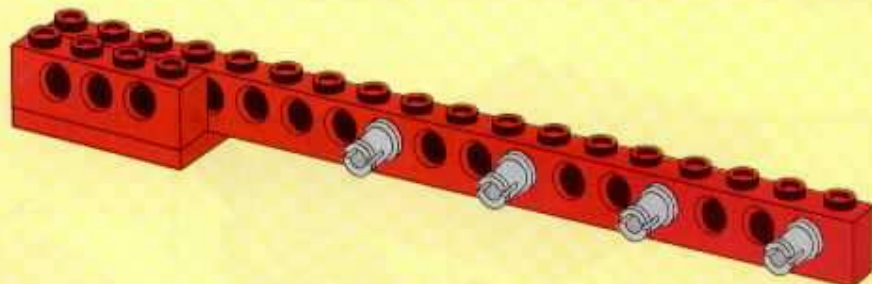

3

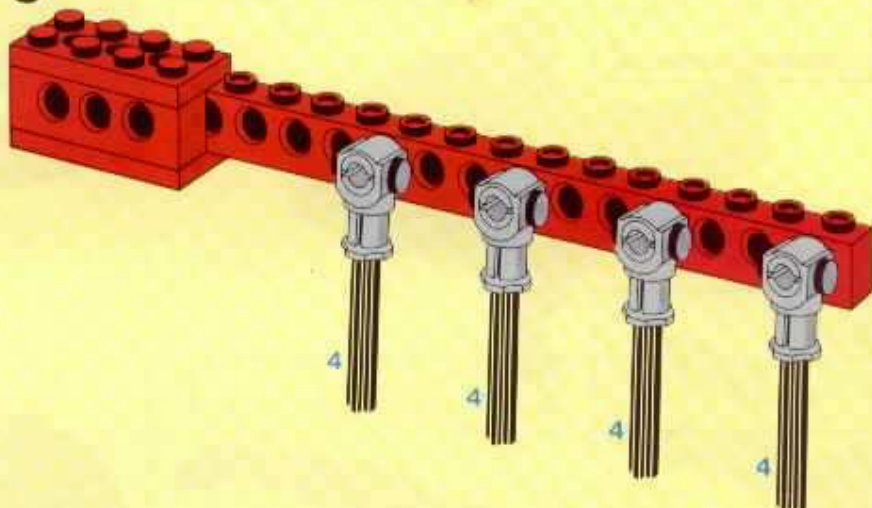

9

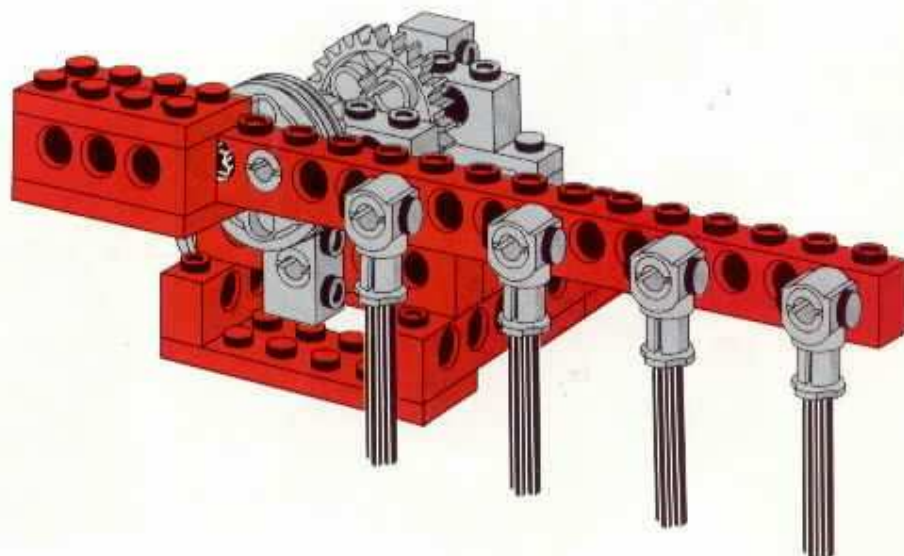

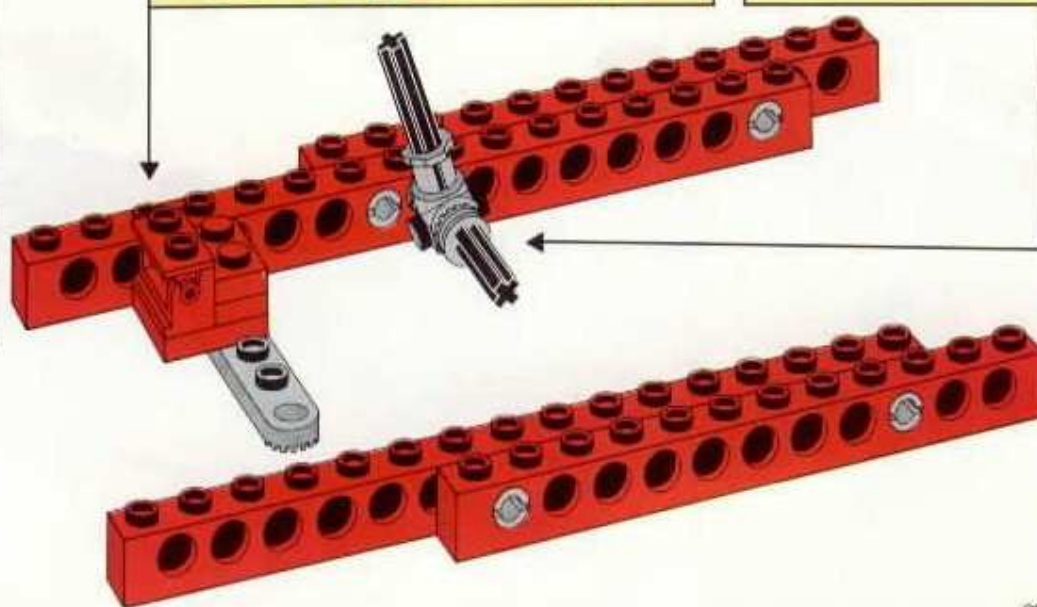
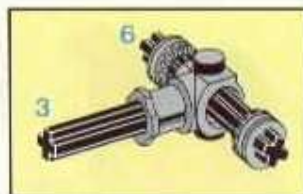
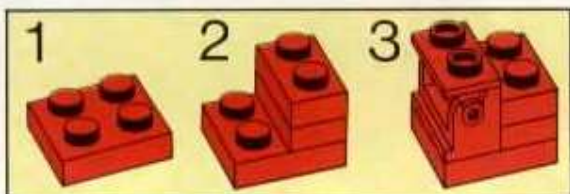
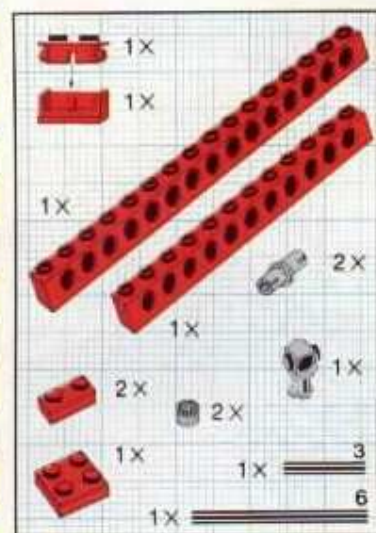
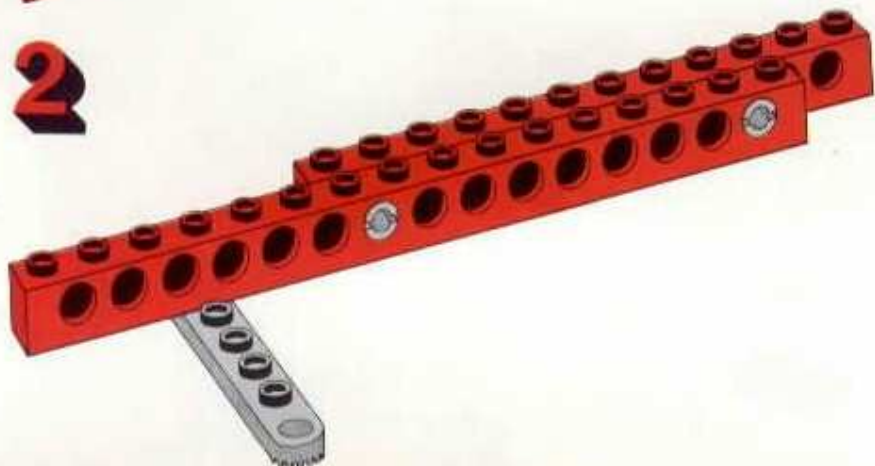
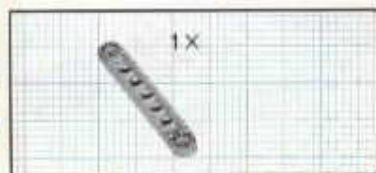
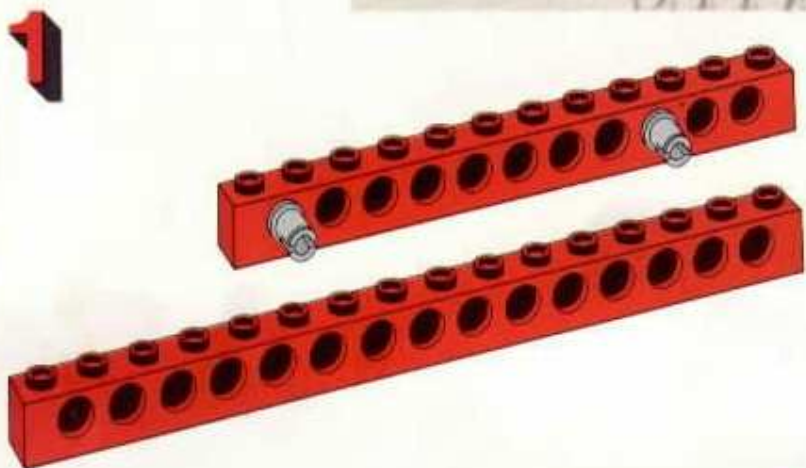
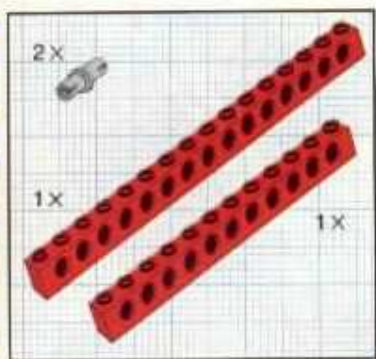

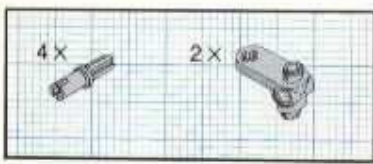

4

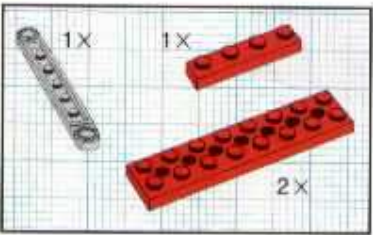
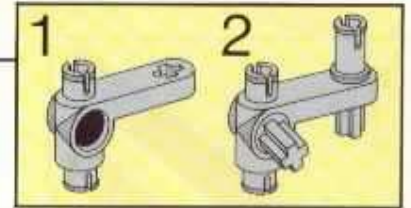
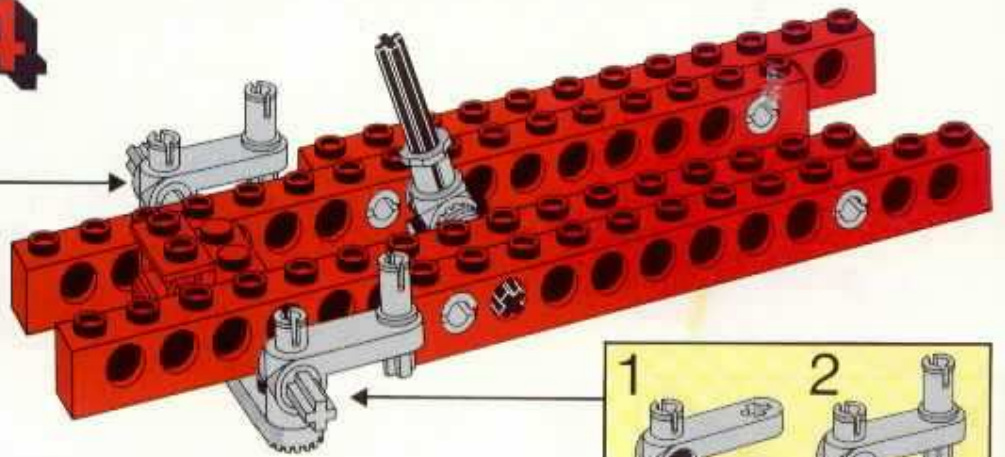
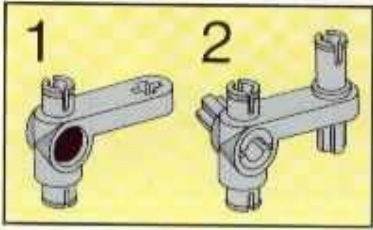

5

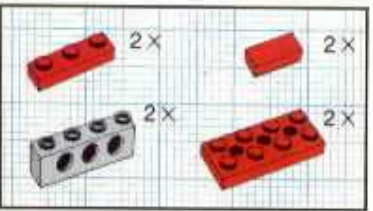
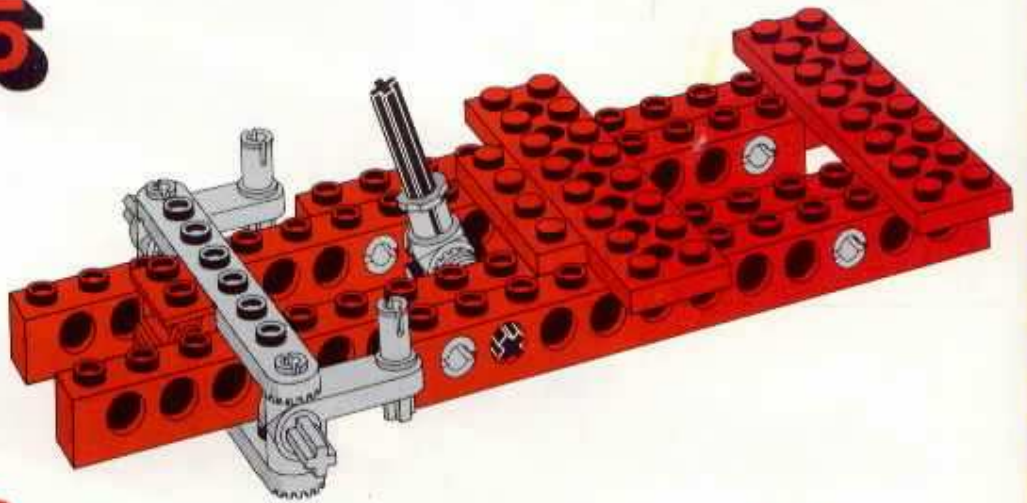

6

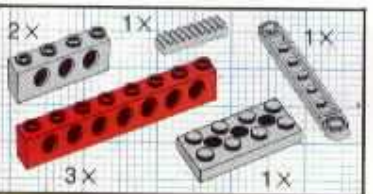
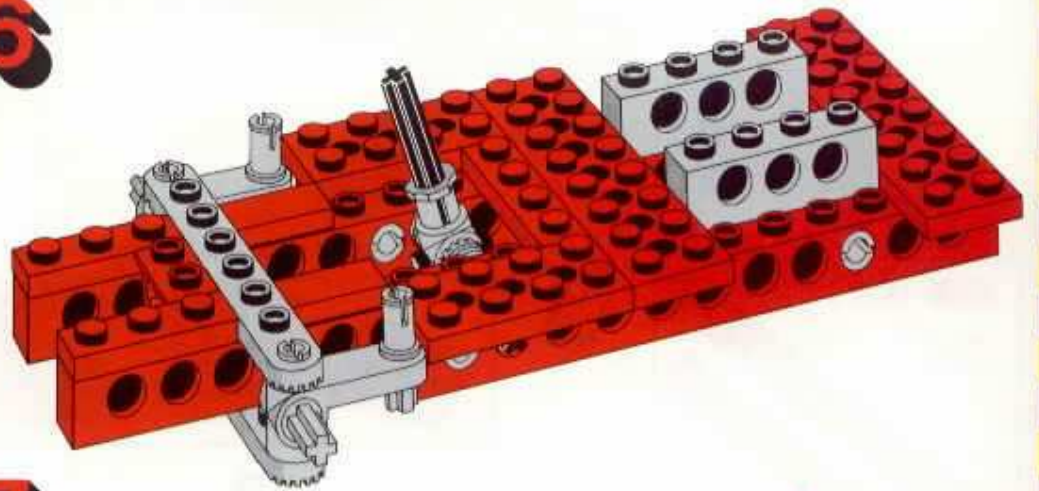

7

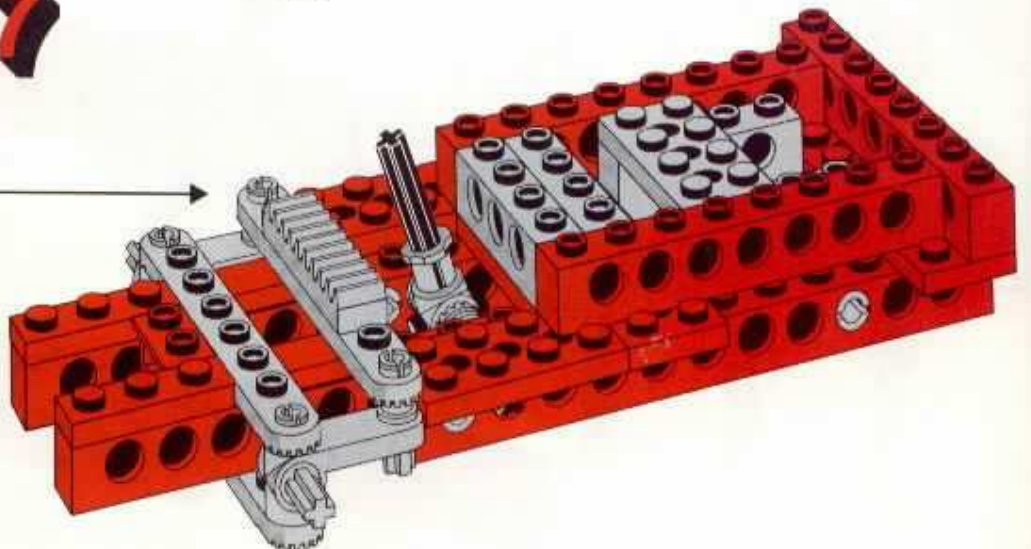
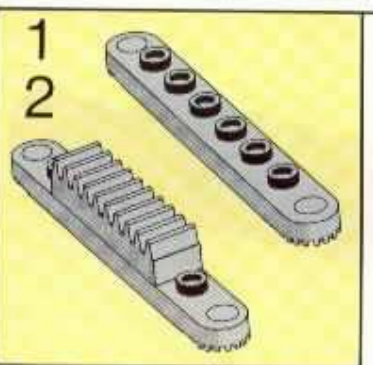

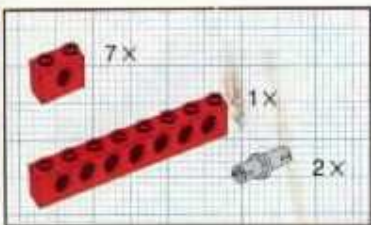

8

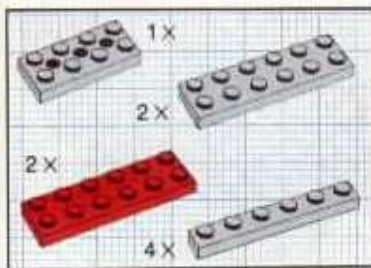
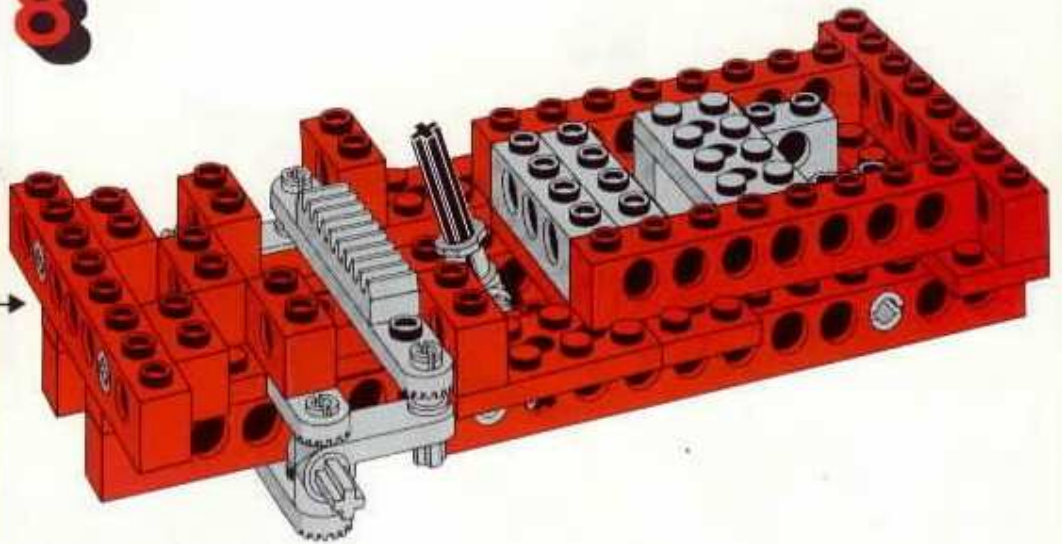
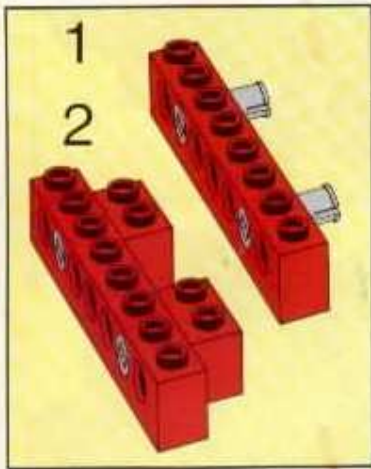

9

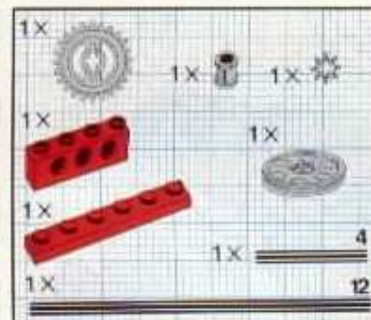
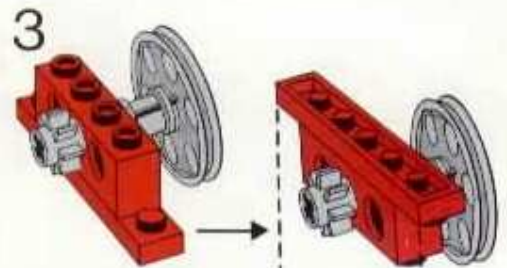
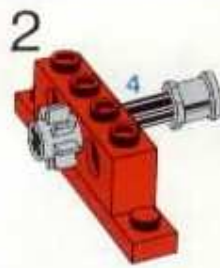
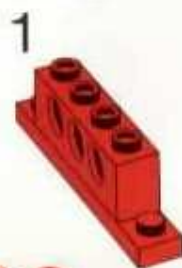
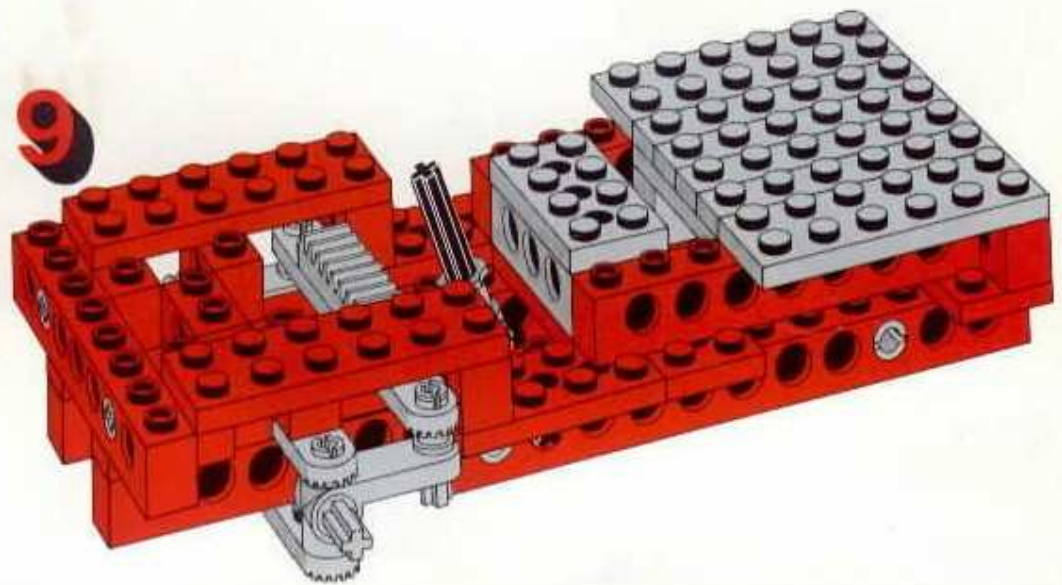

10

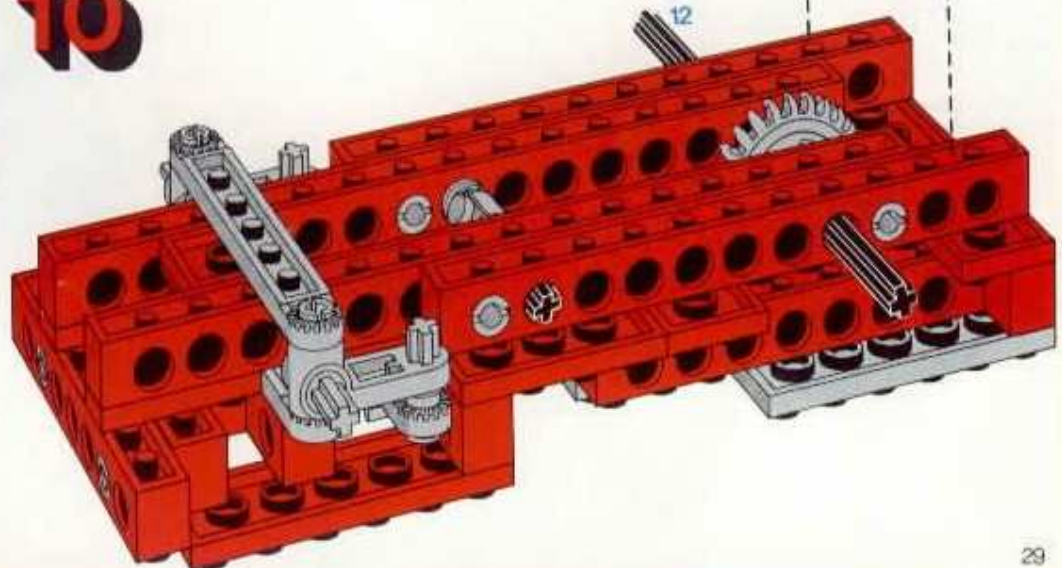

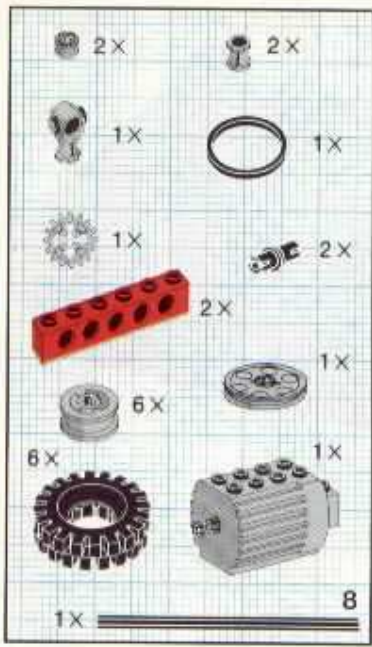

11

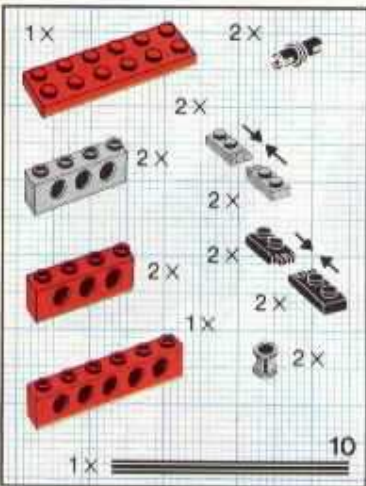
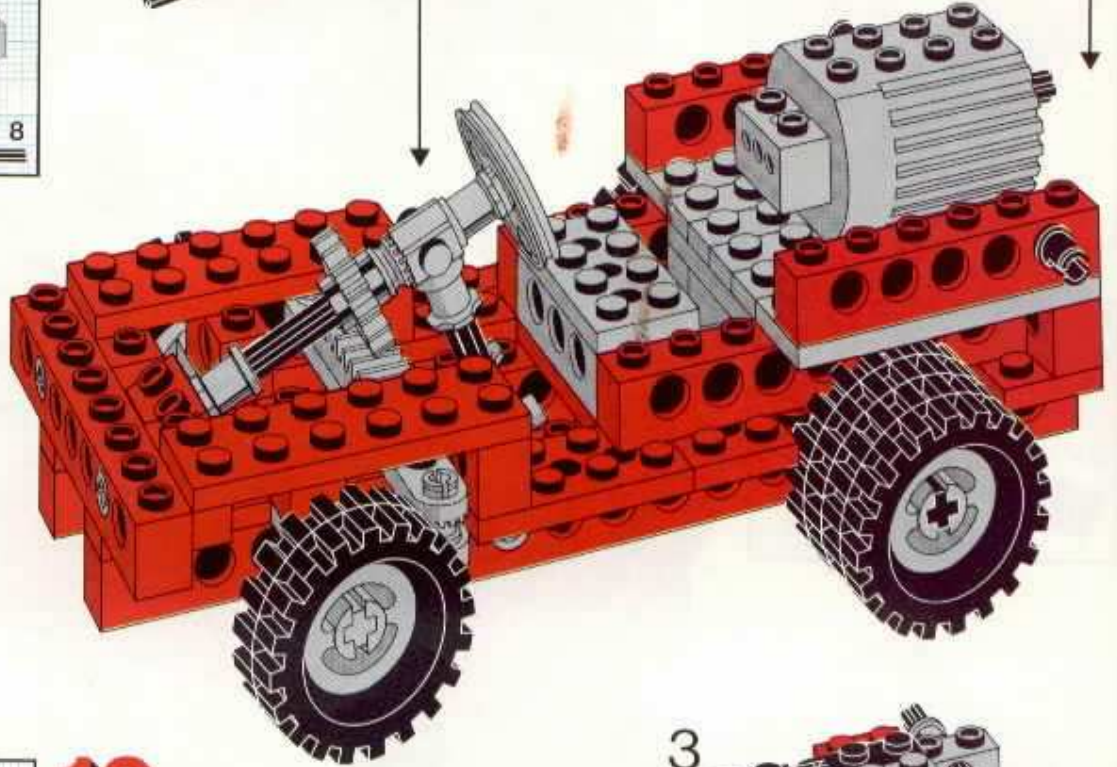
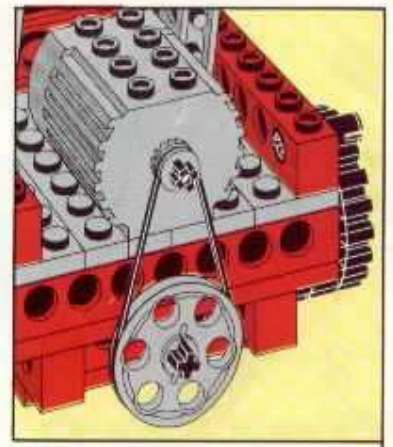
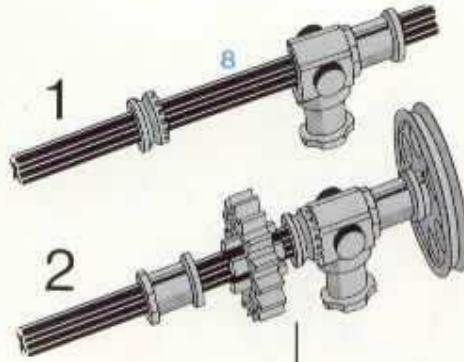

12

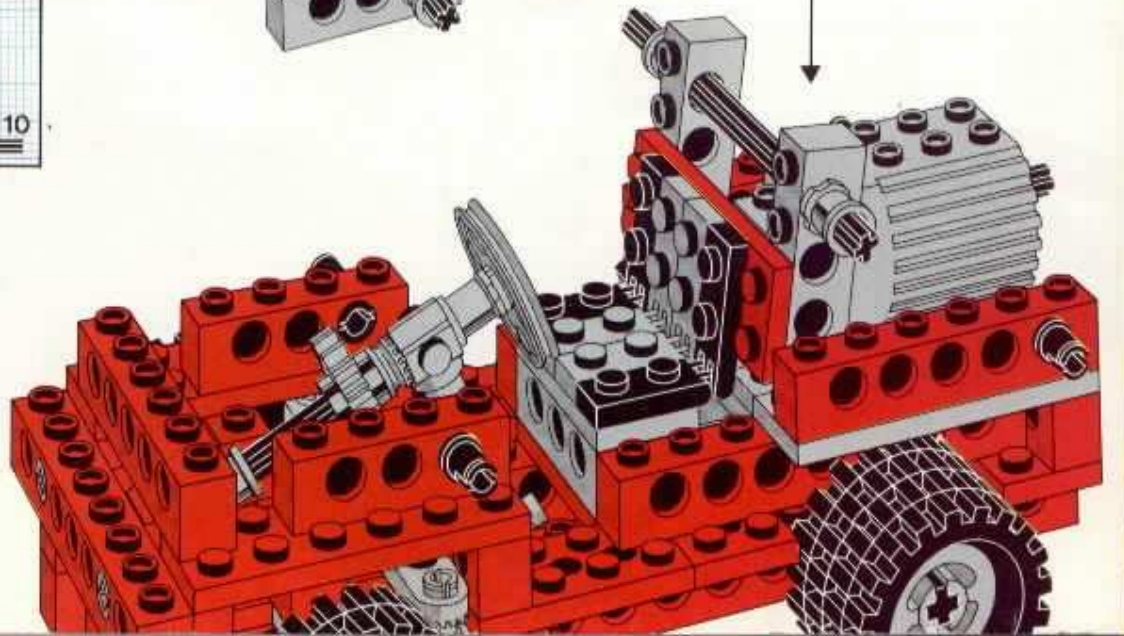
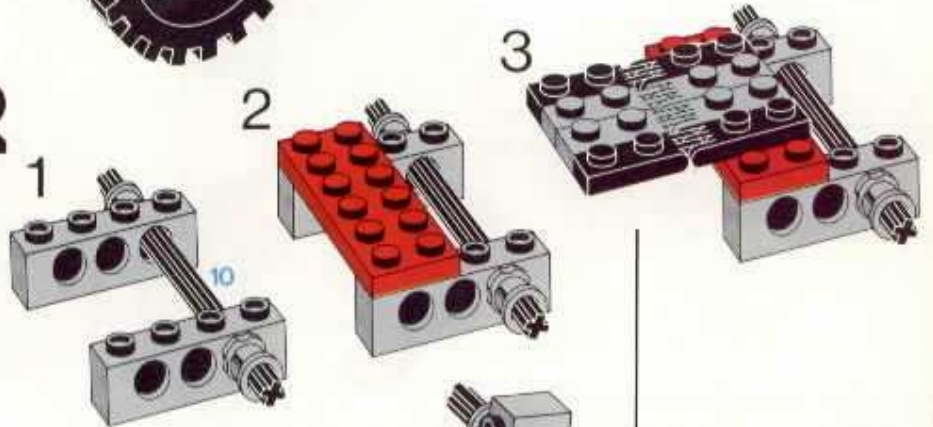

13

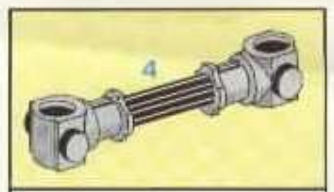
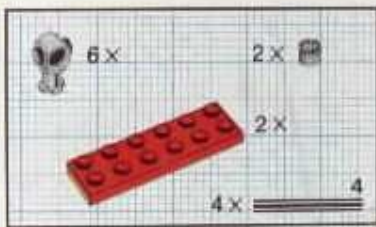

14

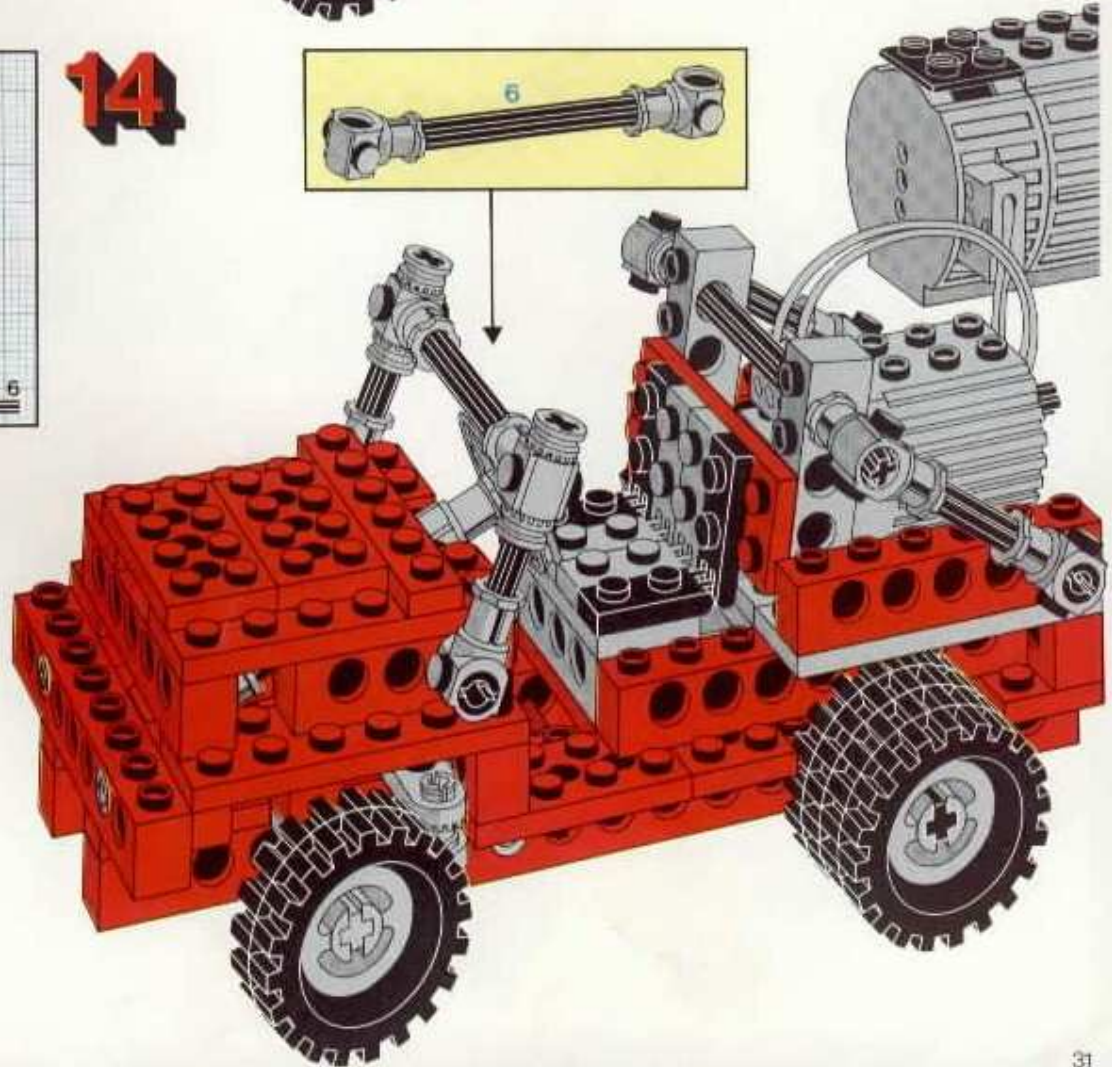
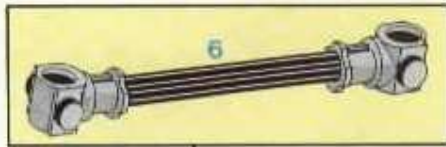
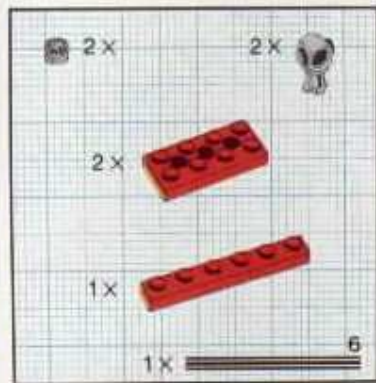

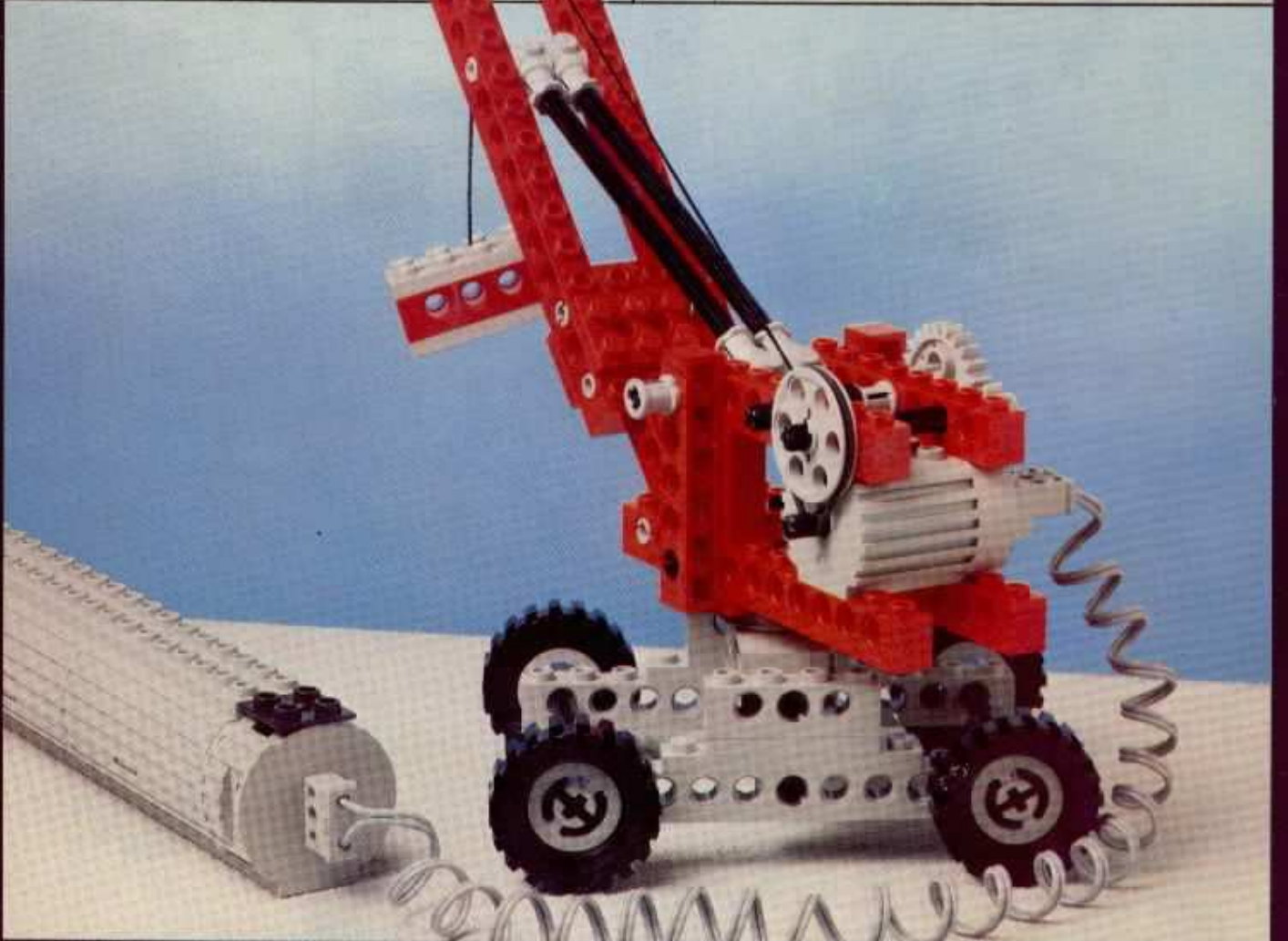
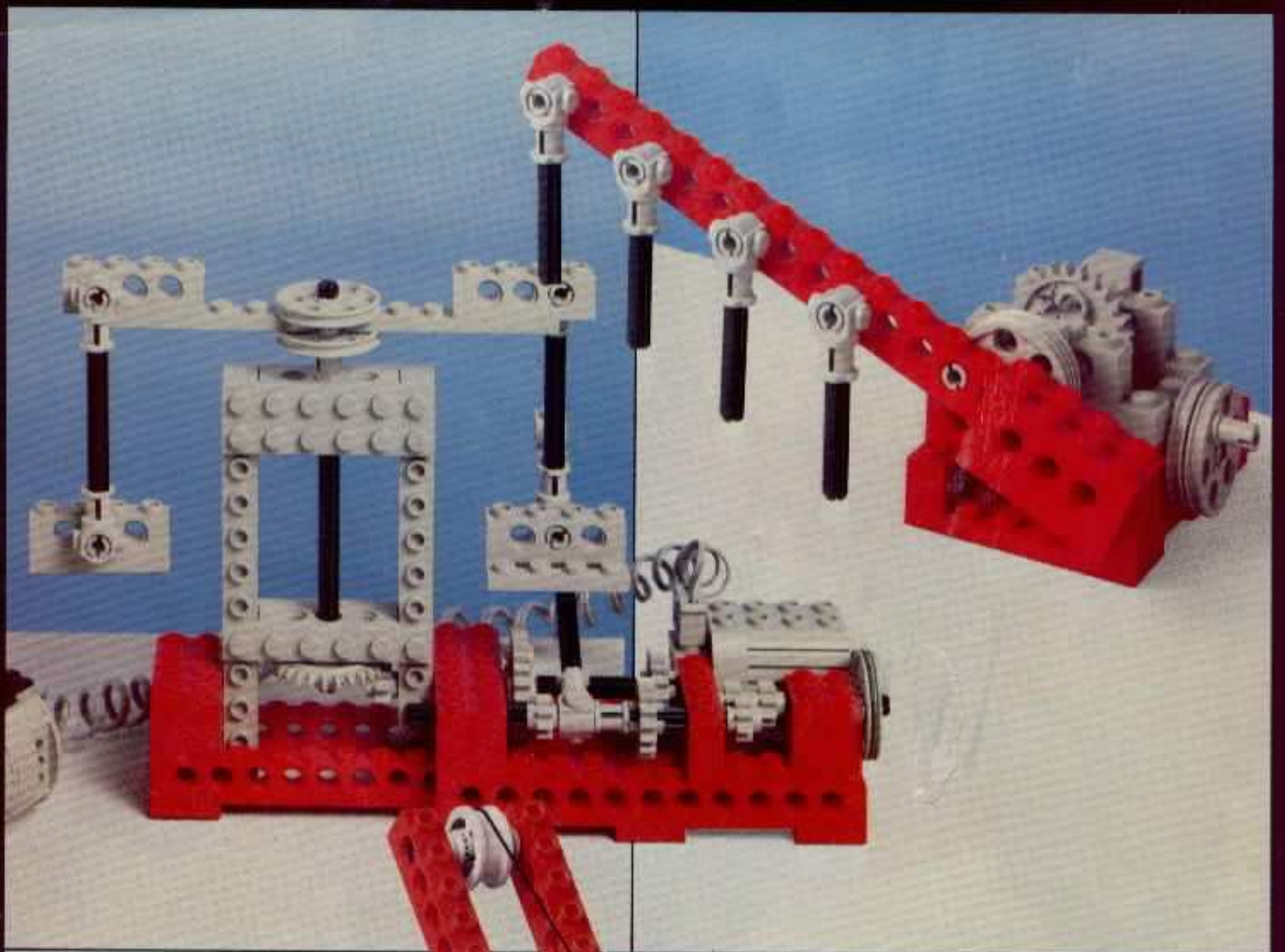

8055

Technic

LEGO

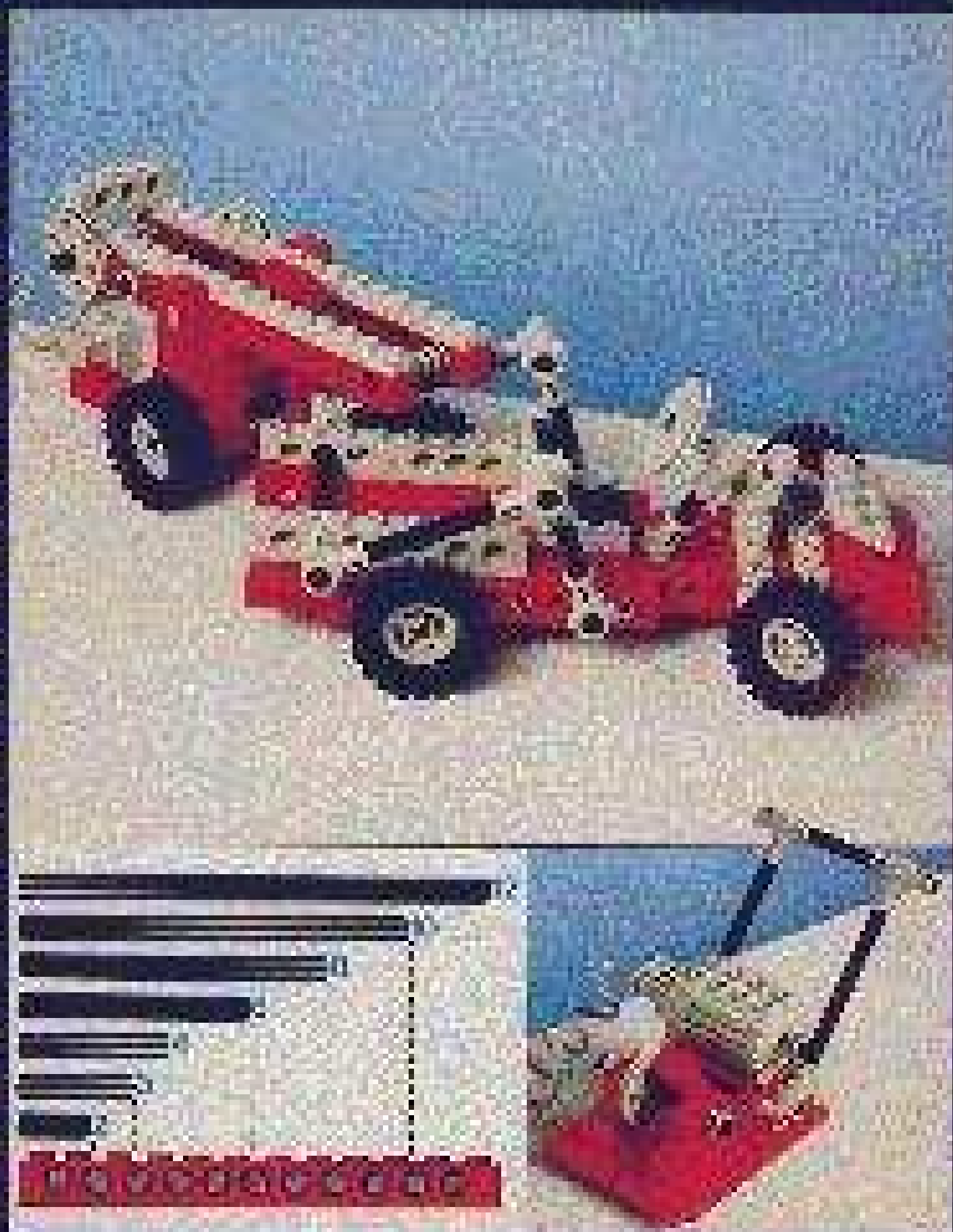

LEGO Technic 8055